

Conformal Orbifold Theories and Braided Crossed G -Categories

Michael Müger^{*,**}

Korteweg-de Vries Institute for Mathematics, University of Amsterdam, The Netherlands.
E-mail: mmueger@science.uva.nl

Received: 5 April 2004 / Accepted: 28 September 2004
Published online: 12 February 2005 – © Springer-Verlag 2005

Dedicated to Detlev Buchholz on the occasion of his sixtieth birthday

Abstract: The aim of the paper is twofold. First, we show that a quantum field theory A living on the line and having a group G of inner symmetries gives rise to a category $G\text{-Loc}A$ of twisted representations. This category is a braided crossed G -category in the sense of Turaev [60]. Its degree zero subcategory is braided and equivalent to the usual representation category $\text{Rep } A$. Combining this with [29], where $\text{Rep } A$ was proven to be modular for a nice class of rational conformal models, and with the construction of invariants of G -manifolds in [60], we obtain an equivariant version of the following chain of constructions: Rational CFT \rightsquigarrow modular category \rightsquigarrow 3-manifold invariant.

Secondly, we study the relation between $G\text{-Loc}A$ and the braided (in the usual sense) representation category $\text{Rep } A^G$ of the orbifold theory A^G . We prove the equivalence $\text{Rep } A^G \simeq (G\text{-Loc}A)^G$, which is a rigorous implementation of the insight that one needs to take the twisted representations of A into account in order to determine $\text{Rep } A^G$. In the opposite direction we have $G\text{-Loc}A \simeq \text{Rep } A^G \rtimes \mathcal{S}$, where $\mathcal{S} \subset \text{Rep } A^G$ is the full subcategory of representations of A^G contained in the vacuum representation of A , and \rtimes refers to the Galois extensions of braided tensor categories of [44, 48].

Under the assumptions that A is completely rational and G is finite we prove that A has g -twisted representations for every $g \in G$ and that the sum over the squared dimensions of the simple g -twisted representations for fixed g equals $\dim \text{Rep } A$. In the holomorphic case (where $\text{Rep } A \simeq \text{Vect}_{\mathbb{C}}$) this allows to classify the possible categories $G\text{-Loc}A$ and to clarify the rôle of the twisted quantum doubles $D^{\omega}(G)$ in this context, as will be done in a sequel. We conclude with some remarks on non-holomorphic orbifolds and surprising counterexamples concerning permutation orbifolds.

* Supported by NWO through the “pioneer” project no. 616.062.384 of N. P. Landsman.

** Department of Mathematics, Radboud University, Nijmegen, The Netherlands. E-mail: mueger@math.ru.nl

1. Introduction

It is generally accepted that a chiral conformal field theory (CFT) should have a braided tensor category of representations, cf. e.g. [41]. In order to turn this idea into rigorous mathematics one needs an axiomatic formulation of chiral CFTs and their representations, the most popular framework presently being the one of vertex operator algebras (VOAs), cf. [26]. It is, however, quite difficult to define a tensor product of representations of a VOA, let alone to construct a braiding. These difficulties do not arise in the operator algebraic approach to CFT, reviewed e.g. in [22]. (For the general setting see [24].) In the latter approach it has even been possible to give a model-independent proof of modularity (in the sense of [59]) of the representation category for a natural class of rational CFTs [29]. This class contains the $SU(n)$ WZW-models and the Virasoro models for $c < 1$ and it is closed w.r.t. direct products, finite extensions and subtheories and coset constructions. Knowing modularity of $\text{Rep } A$ for rational chiral CFTs is very satisfactory, since it provides a rigorous way of associating an invariant of 3-manifolds with the latter [59].

It should be mentioned that the strengths and weaknesses of the two axiomatic approaches are somewhat complementary. The operator algebraic approach has failed so far to reproduce all the insights concerning the conformal characters afforded by other approaches. (A promising step towards a fusion of the two axiomatic approaches has been taken in [61].)

Given a quantum field theory (QFT) A , conformal or not, it is interesting to consider actions of a group G by global symmetries, i.e. by automorphisms commuting with the space-time symmetry. In this situation it is natural to study the relation between the categories $\text{Rep } A$ and $\text{Rep } A^G$, where A^G is the G -fixed subtheory of A . In view of the connection with string theory, in which the fixpoint theory has a geometric interpretation, one usually speaks of ‘orbifold theories’.

In fact, for a quantum field theory A in Minkowski space of $d \geq 2 + 1$ dimensions and a certain category $DHR(A)$ of representations [16] – admittedly too small to be physically realistic – the following have been shown [19]: (1) $DHR(A)$ is symmetric monoidal, semisimple and rigid, (2) there exists a compact group G such that $DHR(A) \simeq \text{Rep } G$, (3) there exists a QFT F on which G acts by global symmetries and such that (4) $F^G \cong A$, (5) the vacuum representation of F , restricted to A , contains all irreducible representations in $DHR(A)$, (6) all intermediate theories $A \subset B \subset F$ are of the form $B = F^H$ for some closed $H \triangleleft G$, and (7) $DHR(F)$ is trivial. All this should be understood as a Galois theory for quantum fields.

These results cannot possibly hold in low-dimensional CFT for the simple reason that a non-trivial modular category is never symmetric. Turning to models with symmetry group G , we will see that G acts on the category $\text{Rep } A$ and that $\text{Rep } A^G$ contains the G -fixed subcategory $(\text{Rep } A)^G$ as a full subcategory. (The objects of the latter are precisely the representations of A^G that are contained in the restriction to A^G of a representation of A .) Now it is known from models, cf. e.g. [11], that $(\text{Rep } A)^G \not\cong \text{Rep } A^G$ whenever G is non-trivial. This can be quantified as $\dim \text{Rep } A^G = |G| \dim(\text{Rep } A)^G = |G|^2 \dim \text{Rep } A$, cf. e.g. [64, 45]. Furthermore, it has been known at least since [11] that $\text{Rep } A^G$ is not determined completely by $\text{Rep } A$. This is true even in the simplest case, where $\text{Rep } A$ is trivial but $\text{Rep } A^G$ depends on an additional piece of information pertaining to the ‘twisted representations’ of A . (Traditionally, cf. in particular [11, 12, 10], it is believed that this piece of information is an element of $H^3(G, \mathbb{T})$, but the situation is considerably more complicated as we indicate in Subsect. 4.2 and will be elaborated further in a sequel [49] to this work.

Already this simplest case shows that a systematic approach is needed. It turns out that the right structure to use are the braided crossed G -categories recently introduced for the purposes of algebraic [7] and differential [60] topology. Roughly speaking, a crossed G -category is a tensor category carrying a G -grading ∂ (on the objects) and a compatible G -action γ . A braiding is a family of isomorphisms $(c_{X,Y} : X \otimes Y \rightarrow {}^X Y \otimes X)$, where ${}^X Y = \gamma_{\partial X}(Y)$, satisfying a suitably generalized form of the braid identities. In Sect. 2 we will show that a QFT on the line carrying a G -action defines a braided crossed G -category $G\text{-Loc}A$ whose degree zero part is $\text{Rep} A$. After some further preparation it will turn out that the additional information contained in $G\text{-Loc}A$ is precisely what is needed in order to compute $\text{Rep} A^G$. On the one hand, it is easy to define a ‘restriction functor’ $R : (G\text{-Loc}A)^G \rightarrow \text{Rep} A^G$, cf. Subsect. 3.1. On the other hand, the procedure of ‘ α -induction’ from [35, 62, 4] provides a functor $E : \text{Rep} A^G \rightarrow (G\text{-Loc}A)^G$ that is inverse to R , proving the braided equivalence

$$\text{Rep} A^G \simeq (G\text{-Loc}A)^G. \tag{1.1}$$

Yet more can be said. We recall that given a semisimple rigid braided tensor category \mathcal{C} over an algebraically closed field of characteristic zero and a full symmetric subcategory \mathcal{S} that is even (all objects have twist $+1$ and thus there exists a compact group G such that $\mathcal{S} \simeq \text{Rep} G$) there exists a tensor category $\mathcal{C} \rtimes \mathcal{S}$ together with a faithful tensor functor $\iota : \mathcal{C} \rightarrow \mathcal{C} \rtimes \mathcal{S}$. $\mathcal{C} \rtimes \mathcal{S}$ is braided if \mathcal{S} is contained in the center $\mathcal{Z}_2(\mathcal{C})$ of \mathcal{C} [5, 44] and a braided crossed G -category in general [48, 30]. Applying this to the full subcategory $\mathcal{S} \subset \text{Rep} A^G$ of those representations that are contained in the vacuum representation of A , we show that the functor E factors as $E = (\text{Rep} A^G \xrightarrow{\iota} \text{Rep} A^G \rtimes \mathcal{S} \xrightarrow{F} G\text{-Loc}A)$, where $F : \text{Rep} A^G \rtimes \mathcal{S} \rightarrow G\text{-Loc}A$ is a full and faithful functor of braided crossed G -categories. For finite G we prove the latter to be an equivalence:

$$G\text{-Loc}A \simeq \text{Rep} A^G \rtimes \mathcal{S}. \tag{1.2}$$

Thus the pair $(\text{Rep} A^G, \mathcal{S})$ contains the same information as $G\text{-Loc}A$ (with its structure as braided crossed G -category). We conclude that the categorical framework of [48] and the quantum field theoretical setting of Sect. 2 are closely related.

In [29] it was proven that $\text{Rep} A$ is a modular category [59] if A is completely rational. In Sect. 4 we use this result to prove that a completely rational theory carrying a finite symmetry G always admits g -twisted representations for every $g \in G$. This is an analogue of a similar result [13] for vertex operator algebras. (However, two issues must be noted. First, it is not yet known when a finite orbifold \mathcal{V}^G of a – suitably defined – rational VOA \mathcal{V} is again rational, making it at present necessary to assume rationality of \mathcal{V}^G . Secondly, no full construction of a braided G -crossed category of twisted representations has been given in the VOA framework.) In fact we have the stronger result

$$\sum_{X_i \in (G\text{-Loc}A)_g} d(X_i)^2 = \sum_{X_i \in \text{Loc}A} d(X_i)^2 =: \dim \text{Loc}A \quad \forall g \in G,$$

where the summations run over the isoclasses of simple objects in the respective categories.

Let us briefly mention some interesting related works. In the operator algebraic setting, conformal orbifold models were considered in particular in [64, 37, 27]. In [64] it is shown that A^G is completely rational if A is completely rational and G is finite, a result that we will use. The other works consider orbifolds in affine models of CFT,

giving a fairly complete analysis of $\text{Rep } A^G$. The overlap with our model independent categorical analysis is small. Concerning the VOA setting we limit ourselves to mentioning [13, 14] where suitably defined twisted representations of A are considered and their existence is proven for all $g \in G$. Also holomorphic orbifolds are considered. The works [32, 30, 31] are predominantly concerned with categorical considerations, but the connection with VOAs and their orbifolds is outlined in [32, Sect. 5], a more detailed treatment being announced. [30, II] and [31] concern similar matters as [44, 48] from a somewhat different perspective. All in all it seems fair to say, however, that no complete proofs of analogues of our Theorems 2.21, 3.18 and 4.2 for VOAs have been published.

The paper is organized as follows. In Sect. 2 we show that a chiral conformal field theory A carrying a G -action gives rise to a braided crossed G -category $G\text{-Loc}A$ of (twisted) representations. Even though the construction is a straightforward generalization of the procedure in the ungraded case, we give complete details in order to make the constructions accessible to readers who are unfamiliar with algebraic QFT. We first consider theories on the line, requiring only the minimal set of axioms necessary to define $G\text{-Loc}A$. We then turn to theories on the circle, establish the connection between the two settings and review the results of [29] on completely rational theories. In Sect. 3 we study the relation between the category $G\text{-Loc}A$ and the representation category $\text{Rep } A^G$ of the orbifold theory A^G , proving (1.1) and (1.2). In Sect. 4 we focus on completely rational CFTs [29] and finite groups, obtaining stronger results. We give a preliminary discussion of the ‘holomorphic’ case where $\text{Rep } A$ is trivial. A complete analysis of this case is in preparation and will appear elsewhere [49]. We conclude with some comments and counterexamples concerning orbifolds of non-holomorphic models.

Most results of this paper were announced in [45], which seems to be the first reference to point out the relevance of braided crossed G -categories in the context of orbifold CFT.

2. Braided Crossed G -Categories in Chiral CFT

2.1. QFT on \mathbb{R} and twisted representations. In this subsection we consider QFTs living on the line \mathbb{R} . We begin with some definitions. Let \mathcal{K} be the set of intervals in \mathbb{R} , i.e. the bounded connected open subsets of \mathbb{R} . For $I, J \in \mathcal{K}$ we write $I < J$ and $I > J$ if $I \subset (-\infty, \inf J)$ or $I \subset (\sup J, +\infty)$, respectively. We write $I^\perp = \mathbb{R} - \bar{I}$.

For any Hilbert space \mathcal{H} , $\mathcal{B}(\mathcal{H})$ is the set of bounded linear operators on \mathcal{H} , and for $M \subset \mathcal{B}(\mathcal{H})$ we write $M^* = \{x^* \mid x \in M\}$ and $M' = \{x \in \mathcal{B}(\mathcal{H}) \mid xy = yx \ \forall y \in M\}$. A von Neumann algebra (on \mathcal{H}) is a set $M \subset \mathcal{B}(\mathcal{H})$ such that $M = M^* = M''$, thus in particular it is a unital $*$ -algebra. A factor is a von Neumann algebra M such that $Z(M) \equiv M \cap M' = \mathbb{C}\mathbf{1}$. A factor M (on a separable Hilbert space) is of type III iff for every $p = p^2 = p^* \in M$ there exists $v \in M$ such that $v^*v = \mathbf{1}$, $vv^* = p$. If M, N are von Neumann algebras then $M \vee N$ is the smallest von Neumann algebra containing $M \cup N$, in fact: $M \vee N = (M' \cap N)'$.

Definition 2.1. A QFT on \mathbb{R} is a triple $(\mathcal{H}_0, A, \Omega)$, usually simply denoted by A , where

1. \mathcal{H}_0 is a separable Hilbert space with a distinguished non-zero vector Ω ,
2. A is an assignment $\mathcal{K} \ni I \mapsto A(I) \subset \mathcal{B}(\mathcal{H}_0)$, where $A(I)$ is a type III factor.

These data are required to satisfy

- *Isotony:* $I \subset J \Rightarrow A(I) \subset A(J)$,
- *Locality:* $I \subset J^\perp \Rightarrow A(I) \subset A(J)'$,

- *Irreducibility:* $\bigvee_{I \in \mathcal{K}} A(I) = \mathcal{B}(\mathcal{H}_0)$ (equivalently, $\bigcap_{I \in \mathcal{K}} A(I)' = \mathbb{C}\mathbf{1}$),
- *Strong additivity:* $A(I) \vee A(J) = A(K)$ whenever $I, J \in \mathcal{K}$ are adjacent, i.e. $\bar{I} \cap \bar{J} = \{p\}$, and $K = I \cup J \cup \{p\}$,
- *Haag duality* $A(I^\perp)' = A(I)$ for all $I \in \mathcal{K}$,

where we have used the unital $*$ -algebras

$$A_\infty = \bigcup_{I \in \mathcal{K}} A(I) \subset \mathcal{B}(\mathcal{H}_0),$$

$$A(I^\perp) = \text{Alg} \{A(J), J \in \mathcal{K}, I \cap J = \emptyset\} \subset A_\infty.$$

Remark 2.2. 1. Note that A_∞ is the algebraic inductive limit, no closure is involved. We have $Z(A_\infty) = \mathbb{C}\mathbf{1}$ as a consequence of the fact that the $A(I)$ are factors.

2. The above axioms are designed to permit a rapid derivation of the desired categorical structure. In Subsect. 2.4 we will consider a set of axioms that is more natural from the mathematical as well as physical perspective.

Our aim is now to associate a strict braided crossed G-category $G\text{-Loc } A$ to any QFT on \mathbb{R} equipped with a G-action on A in the sense of the following :

Definition 2.3. Let $(\mathcal{H}_0, A, \Omega)$ be a QFT on \mathbb{R} . A topological group G acts on A if there is a strongly continuous unitary representation $V : G \rightarrow \mathcal{U}(\mathcal{H}_0)$ such that

1. $\beta_g(A(I)) = A(I) \forall g \in G, I \in \mathcal{K}$, where $\beta_g(x) = V(g)xV(g)^*$.
2. $V(g)\Omega = \Omega$.
3. If $\beta_g \upharpoonright A(I) = \text{id}$ for some $I \in \mathcal{K}$ then $g = e$.

Remark 2.4. 1. Condition 3 will be crucial for the definition of the G-grading on $G\text{-Loc } A$.

2. In this section the topology of G is not taken into account. In Sect. 3 we will mostly be interested in finite groups, but we will also comment on infinite compact groups.

The subsequent considerations are straightforward generalizations of the well known theory [16, 20, 21] for $G = \{e\}$. Since modifications of the latter are needed throughout – and also in the interest of the non-expert reader – we prefer to develop the case for non-trivial G from scratch. Readers who are unfamiliar with the following well-known result are encouraged to do the easy verifications. (We stick to the tradition of denoting the objects of $\text{End } B$ by lower case Greek letters.)

Definition/Proposition 2.5. Let B be a unital $*$ -subalgebra of $\mathcal{B}(\mathcal{H})$. Let $\text{End } B$ be the category whose objects ρ, σ, \dots are unital $*$ -algebra homomorphisms from B into itself. With

$$\begin{aligned} \text{Hom}(\rho, \sigma) &= \{s \in B \mid s\rho(x) = \sigma(x)s \forall x \in B\}, \\ t \circ s &= ts, \quad s \in \text{Hom}(\rho, \sigma), t \in \text{Hom}(\sigma, \eta), \\ \rho \otimes \sigma &= \rho(\sigma(\cdot)), \\ s \otimes t &= s\rho(t) = \rho'(t)s, \quad s \in \text{Hom}(\rho, \rho'), t \in \text{Hom}(\sigma, \sigma'), \end{aligned}$$

$\text{End } B$ is a \mathbb{C} -linear strict tensor category with unit $\mathbf{1} = \text{id}_B$ and positive $*$ -operation. We have $\text{End } \mathbf{1} = Z(B)$.

We now turn to the definition of $G\text{-Loc } A$ as a full subcategory of $\text{End } A_\infty$.

Definition 2.6. Let $I \in \mathcal{K}$, $g \in G$. An object $\rho \in \text{End } A_\infty$ is called g -localized in I if

$$\begin{aligned} \rho(x) &= x && \forall J < I, x \in A(J), \\ \rho(x) &= \beta_g(x) && \forall J > I, x \in A(J). \end{aligned}$$

ρ is g -localized if it is g -localized in some $I \in \mathcal{K}$. A g -localized $\rho \in \text{End } A_\infty$ is transportable if for every $J \in \mathcal{K}$ there exists $\rho' \in \text{End } A_\infty$, g -localized in J , such that $\rho \cong \rho'$ (in the sense of unitary equivalence in $\text{End } A_\infty$).

Remark 2.7. 1. If ρ is g -localized in I and $J \supset I$ then ρ is g -localized in J .
 2. Direct sums of transportable morphisms are transportable.
 3. If ρ is g -localized and h -localized then $g = h$.

Proof. By 1, there exists $I \in \mathcal{K}$ such that ρ is g -localized in I and h -localized in I . If $J > I$ then $\rho \upharpoonright A(J) = \beta_g = \beta_h$, and Condition 3 of Definition 2.3 implies $g = h$. \square

Definition 2.8. $G\text{-Loc } A$ is the full subcategory of $\text{End } A_\infty$ whose objects are finite direct sums of G -localized transportable objects of $\text{End } A_\infty$. Thus $\rho \in \text{End } A_\infty$ is in $G\text{-Loc } A$ iff there exists a finite set Δ and, for all $i \in \Delta$, there exist $g_i \in G$, $\rho_i \in \text{End } A_\infty$ g_i -localized transportable, and $v_i \in \text{Hom}(\rho_i, \rho)$ such that $v_i^* \circ v_j = \delta_{ij}$ and

$$\rho = \sum_i v_i \rho_i(\cdot) v_i^*.$$

We say $\rho \in G\text{-Loc } A$ is G -localized in $I \in \mathcal{K}$ if there exists a decomposition as above where all ρ_i are g_i -localized in I and transportable and $v_i \in A(I) \forall i$.

For $g \in G$, let $(G\text{-Loc } A)_g$ be the full subcategories of $G\text{-Loc } A$ consisting of those ρ that are g -localized, and let $(G\text{-Loc } A)_{\text{hom}}$ be the union of the $(G\text{-Loc } A)_g$, $g \in G$. We write $\text{Loc } A = (G\text{-Loc } A)_e$.

For $g \in G$ define $\gamma_g \in \text{Aut}(G\text{-Loc } A)$ by

$$\begin{aligned} \gamma_g(\rho) &= \beta_g \rho \beta_g^{-1}, \\ \gamma_g(s) &= \beta_g(s), \quad s \in \text{Hom}(\rho, \sigma) \subset A_\infty. \end{aligned}$$

Definition 2.9. Let G be a (discrete) group. A strict crossed G -category is a strict tensor category \mathcal{D} together with

- a full tensor subcategory $\mathcal{D}_{\text{hom}} \subset \mathcal{D}$ of homogeneous objects,
- a map $\partial : \text{Obj } \mathcal{D}_{\text{hom}} \rightarrow G$ constant on isomorphism classes,
- a homomorphism $\gamma : G \rightarrow \text{Aut } \mathcal{D}$ (monoidal self-isomorphisms of \mathcal{D})

such that

1. $\partial(X \otimes Y) = \partial X \partial Y$ for all $X, Y \in \mathcal{D}_{\text{hom}}$,
2. $\gamma_g(\mathcal{D}_h) \subset \mathcal{D}_{ghg^{-1}}$, where $\mathcal{D}_g \subset \mathcal{D}_{\text{hom}}$ is the full subcategory $\partial^{-1}(g)$.

If \mathcal{D} is additive we require that every object of \mathcal{D} be a direct sum of objects in \mathcal{D}_{hom} .

Proposition 2.10. $G\text{-Loc } A$ is a \mathbb{C} -linear crossed G -category with $\text{End } \mathbf{1} = \mathbb{C} \text{Id}_1$, positive $*$ -operation, direct sums and subobjects (i.e. orthogonal projections split).

Proof. The categories $(G\text{-Loc } A)_g$, $g \in G$ are mutually disjoint by Remark 2.7.3. This allows to define the map $\partial : \text{Obj } (G\text{-Loc } A)_{\text{hom}} \rightarrow G$ required by Definition 2.9. If ρ is g -localized in I and σ is h -localized in J then $\rho \otimes \sigma = \rho\sigma$ is gh -localized in any $K \in \mathcal{K}$, $K \supset I \cup J$. Thus $G\text{-Loc } A$ is a tensor subcategory of $\text{End } A_\infty$ and Condition 1 of Definition 2.9 holds. By construction, $G\text{-Loc } A$ is additive and every object is a finite direct sum of homogeneous objects. It is obvious that γ_g commutes with \circ and with \otimes on objects. Now,

$$\gamma_g(s \otimes t) = \beta_g(s)\beta_g(\rho(t)) = \beta_g(s)\gamma_g(\rho)(\beta_g(t)) = \gamma_g(s) \otimes \gamma_g(t).$$

Furthermore, if $s \in \text{Hom}(\rho, \sigma)$ then $\beta_g(s)\beta_g\rho(x) = \beta_g\sigma(x)\beta_g(s)$, and replacing $x \rightarrow \beta_g^{-1}(x)$ we find $\beta_g(s) \in \text{Hom}(\gamma_g(\rho), \gamma_g(\sigma))$. Thus γ_g it is a strict monoidal automorphism of $G\text{-Loc } A$. Obviously, the map $g \mapsto \gamma_g$ is a homomorphism. If ρ is h -localized in I and $J > I$ then

$$\gamma_g(\rho) \upharpoonright A(J) = \beta_g\rho\beta_g^{-1} = \beta_g\beta_h\beta_g^{-1},$$

thus $\gamma_g(\rho)$ is ghg^{-1} -localized in I , thus Condition 2 of Definition 2.9 is verified.

$\mathbf{1} = \text{id}_{A_\infty}$ is e -localized, thus in $G\text{-Loc } A$ and $\text{End } \mathbf{1} = Z(A_\infty) = \text{Cid}_1$. Let $p = p^2 = p^* \in \text{End}(\rho)$. There exists $I \in \mathcal{K}$ such that $p \in A(I)$, and by the type III property, cf. 2.24.1, we find $v \in A(I)$ such that $vv^* = p$, $v^*v = \mathbf{1}$. Defining $\rho_1 = v^*\rho(\cdot)v$ we have $v \in \text{Hom}(\rho_1, \rho)$, thus $G\text{-Loc } A$ has subobjects. Finally, for any finite set Δ and any $I \in \mathcal{K}$ we can find $v_i \in A(I)$, $i \in \Delta$ such that $\sum_i v_i v_i^* = \mathbf{1}$, $v_i^* v_j = \delta_{ij} \mathbf{1}$. If $\rho_i \in G\text{-Loc } A$ we find that $\rho = \sum_i v_i \rho_i(\cdot) v_i^*$ is a direct sum. \square

Remark 2.11. Due to the fact that we consider only unital $\rho \in \text{End } A_\infty$, the category $G\text{-Loc } A$ does not have zero objects, thus cannot be additive or abelian. This could be remedied by dropping the unitality condition, but we refrain from doing so since it would unnecessarily complicate the analysis without any real gains.

2.2. The braiding. Before we can construct a braiding for $G\text{-Loc } A$ some preparations are needed.

Lemma 2.12. *If ρ is g -localized in I then $\rho(A(I)) \subset A(I)$ and $\rho \upharpoonright A(I)$ is normal.*

Proof. Let $J < I$ or $J > I$. We have either $\rho \upharpoonright A(J) = \text{id}$ or $\rho \upharpoonright A(J) = \beta_g$. In both cases $\rho(A(J)) = A(J)$, implying $\rho(A(I^\perp)) = A(I^\perp)$. Applying ρ to the equation $[A(I), A(I^\perp)] = \{0\}$ expressing locality we obtain $[\rho(A(I)), A(I^\perp)] = \{0\}$, or $\rho(A(I)) \subset A(I^\perp)' = A(I)$, where we appealed to Haag duality on \mathbb{R} . The last claim follows from the fact that every unital $*$ -endomorphism of a type III factor with separable predual is automatically normal. \square

Lemma 2.13. *Let ρ, σ be g -localized in I . Then $\text{Hom}(\rho, \sigma) \subset A(I)$.*

Proof. Let $s \in \text{Hom}(\rho, \sigma)$. Let $J < I$ and $x \in A(J)$. Then $sx = s\rho(x) = \sigma(x)s = xs$, thus $s \in A(J)'$. If $J > I$ and $x \in A(J)$ we find $s\beta_g(x) = s\rho(x) = \sigma(x)s = \beta_g(x)s$. Since $\beta_g(A(J)) = A(J)$ we again have $s \in A(J)'$. Thus $s \in A(I^\perp)' = A(I)$, by Haag duality on \mathbb{R} . \square

Lemma 2.14. *Let $\rho_i \in G\text{-Loc } A$, $i = 1, 2$ be g_i -localized in I_i , where $I_1 < I_2$. Then*

$$\rho_1 \otimes \rho_2 = \gamma_{g_1}(\rho_2) \otimes \rho_1. \tag{2.1}$$

Proof. We have $I_1 = (a, b), I_2 = (c, d)$, where $b \leq c$. Let $u < a, v > d$ and define $K = (u, c), L = (b, v)$. For $x \in A(K)$ we have $\rho_2(x) = x$ and therefore $\rho_1\rho_2(x) = \rho_1(x)$. By Lemma 2.12 we have $\rho_1(x) \in A(K)$, and since $\gamma_{g_1}(\rho_2)$ is $g_1g_2g_1^{-1}$ -localized in I_2 we find $\gamma_{g_1}(\rho_2)(\rho_1(x)) = \rho_1(x)$. Thus (2.1) holds for $x \in A(K)$. Consider now $x \in A(L)$. By Lemma 2.12 we have $\rho_2(x) \in A(L)$ and thus $\rho_1\rho_2(x) = \beta_{g_1}\rho_2(x)$. On the other hand, $\rho_1(x) = \beta_{g_1}(x)$ and therefore

$$\gamma_{g_1}(\rho_2)\rho_1(x) = \beta_{g_1}\rho_2\beta_{g_1}^{-1}\beta_{g_1}(x) = \beta_{g_1}\rho_2(x),$$

thus (2.1) also holds for $x \in A(L)$. By strong additivity, $A(K) \vee A(L) = A(u, v)$, and by local normality of ρ_1 and ρ_2 , (2.1) holds on $A(u, v)$ whenever $u < a, v > d$, and therefore on all of A_∞ . \square

Remark 2.15. If one drops the assumption of strong additivity then instead of Lemma 2.12 one still has $\overline{\rho}(A(J)) \subset A(J)$ for every $J \supset \bar{I}$. Lemma 2.14 still holds provided $I_1 < I_2$ and $\bar{I}_1 \cap I_2 = \emptyset$.

Recall that for homogeneous σ we write ${}^\sigma\rho = \gamma_{\partial(\sigma)}(\rho)$ as in [60].

Definition 2.16. A braiding for a crossed G -category \mathcal{D} is a family of isomorphisms $c_{X,Y} : X \otimes Y \rightarrow {}^XY \otimes X$, defined for all $X \in \mathcal{D}_{\text{hom}}, Y \in \mathcal{D}$, such that

(i) the diagram

$$\begin{CD} X \otimes Y @>{s \otimes t}>> X' \otimes Y' \\ @V{c_{X,Y}}VV @VV{c_{X',Y'}}V \\ {}^XY \otimes X @>{X_t \otimes s}>> X'Y' \otimes X' \end{CD} \tag{2.2}$$

commutes for all $s : X \rightarrow X'$ and $t : Y \rightarrow Y'$,
 (ii) for all $X, Y \in \mathcal{D}_{\text{hom}}, Z, T \in \mathcal{D}$ we have

$$c_{X,Z \otimes T} = \text{id}_{X_Z} \otimes c_{X,T} \circ c_{X,Z} \otimes \text{id}_T, \tag{2.3}$$

$$c_{X \otimes Y, Z} = c_{X, Y_Z} \otimes \text{id}_Y \circ \text{id}_X \otimes c_{Y,Z}, \tag{2.4}$$

(iii) for all $X \in \mathcal{D}_{\text{hom}}, Y \in \mathcal{D}$ and $k \in G$ we have

$$\gamma_k(c_{X,Y}) = c_{\gamma_k(X), \gamma_k(Y)}. \tag{2.5}$$

Proposition 2.17. G -Loc A admits a unitary braiding c . If ρ_1, ρ_2 are localized as in Lemma 2.14 then $c_{\rho_1, \rho_2} = \text{id}_{\rho_1 \otimes \rho_2} = \text{id}_{\rho_1 \rho_2 \otimes \rho_1}$.

Proof. Let $\rho \in (G\text{-Loc } A)_g, \sigma \in G\text{-Loc } A$ be G -localized in $I, J \in \mathcal{K}$, respectively. Let $\bar{I} < J$. By transportability we can find $\tilde{\rho} \in (G\text{-Loc } A)_g$ localized in \bar{I} and a unitary $u \in \text{Hom}(\rho, \tilde{\rho})$. By Lemma 2.14 we have $\tilde{\rho} \otimes \sigma = \gamma_g(\sigma) \otimes \rho$, thus the composite

$$c_{\rho, \sigma} : \rho \otimes \sigma \xrightarrow{u \otimes \text{id}_\sigma} \tilde{\rho} \otimes \sigma \equiv \gamma_g(\sigma) \otimes \tilde{\rho} \xrightarrow{\text{id}_{\gamma_g(\sigma)} \otimes u^*} \gamma_g(\sigma) \otimes \rho$$

is unitary and a candidate for the braiding. As an element of $A_\infty, c_{\rho, \sigma} = \gamma_g(\sigma)(u^*)u = \beta_g\sigma\beta_g^{-1}(u^*)u$. In order to show that $c_{\rho, \sigma}$ is independent of the choices involved pick

$\tilde{\rho} \in (G\text{-Loc } A)_g$ g -localized in \tilde{I} (we may assume the same localization interval since ρ localized in \tilde{I} is also localized in $\tilde{I} \supset \tilde{I}$) and a unitary $\tilde{u} \in \text{Hom}(\rho, \tilde{\rho})$. In view of Lemma 2.13 we have $u\tilde{u}^* \in \text{Hom}(\tilde{\rho}, \tilde{\rho}) \subset A(\tilde{I})$, implying $\gamma_g(\sigma)(u\tilde{u}^*) = u\tilde{u}^*$. The computation

$$\begin{aligned} c_{\rho, \sigma} &= \gamma_g(\sigma)(u^*)u = \gamma_g(\sigma)(u^*)(u\tilde{u}^*)(\tilde{u}u^*)u \\ &= \gamma_g(\sigma)(u^*(u\tilde{u}^*))(\tilde{u}u^*)u = \gamma_g(\sigma)(\tilde{u}^*)\tilde{u} = \tilde{c}_{\rho, \sigma} \end{aligned}$$

shows that $c_{\rho, \sigma}$ is independent of the chosen $\tilde{\rho}$ and $u \in \text{Hom}(\rho, \tilde{\rho})$.

Now consider $\sigma, \sigma' \in G\text{-Loc } A$ G -localized in J , $\rho \in (G\text{-Loc } A)_g$ and $t \in \text{Hom}(\sigma, \sigma')$. We pick $\tilde{I} < J$, $\tilde{\rho}$ g -localized in \tilde{I} and a unitary $u \in \text{Hom}(\rho, \tilde{\rho})$. We define $c_{\rho, \sigma} = \gamma_g(\sigma)(u^*)u$ and $c_{\rho, \sigma'} = \gamma_g(\sigma')(u^*)u$ as above. The computation

$$\begin{aligned} c_{\rho, \sigma'} \circ \text{id}_\rho \otimes t &= \gamma_g(\sigma')(u^*)u \rho(t) = \beta_g \sigma' \beta_g^{-1}(u^*)u \rho(t) \\ &= \beta_g \sigma' \beta_g^{-1}(u^*)\tilde{\rho}(t)u = \beta_g \sigma' \beta_g^{-1}(u^*)\beta_g(t)u \\ &= \beta_g[\sigma' \beta_g^{-1}(u^*)t]u = \beta_g[t \sigma \beta_g^{-1}(u^*)]u \\ &= \beta_g(t)\beta_g \sigma \beta_g^{-1}(u^*)u = \beta_g(t)\gamma_g(\sigma)(u^*)u \\ &= \beta_g(t) \otimes \text{id}_\rho \circ c_{\rho, \sigma} \end{aligned}$$

proves naturality (2.2) of $c_{\rho, \sigma}$ w.r.t. σ . (In the fourth step $\tilde{\rho}(t) = \beta_g(t)$ is due to $t \in \text{Hom}(\sigma, \sigma') \subset A(J)$, cf. Lemma 2.13, and the fact that ρ' is g -localized in $\tilde{I} < J$.)

Next, let $\rho, \rho' \in (G\text{-Loc } A)_g, s \in \text{Hom}(\rho, \rho')$ and let $\sigma \in G\text{-Loc } A$ be G -localized in J . Pick $\tilde{I} < J$, $\tilde{\rho}, \tilde{\rho}'$ g -localized in \tilde{I} and unitaries $u \in \text{Hom}(\rho, \tilde{\rho}), u' \in \text{Hom}(\rho', \tilde{\rho}')$. Then

$$\begin{aligned} c_{\rho, \sigma'} \circ s \otimes \text{id}_\sigma &= \gamma_g(\sigma)(u'^*)u' s = \gamma_g(\sigma)(u'^*)(u' s u^*)u \\ &= \gamma_g(\sigma)(u'^*(u' s u^*))u = \gamma_g(\sigma)(s u^*)u \\ &= \gamma_g(\sigma)(s)\gamma_g(\sigma)(u^*)u = \text{id}_{\gamma_g(\sigma)} \otimes s \circ c_{\rho, \sigma} \end{aligned}$$

proves naturality of $c_{\rho, \sigma}$ w.r.t. ρ . (Here we used the fact that $\tilde{\rho}, \tilde{\rho}'$ are g -localized in \tilde{I} , implying $u' s u^* \in \text{Hom}(\tilde{\rho}, \tilde{\rho}') \subset A(\tilde{I})$ by Lemma 2.13 and finally $\gamma_g(\sigma)(u' s u^*) = u' s u^*$.)

Next, let $\rho \in (G\text{-Loc } A)_g$ and let $\sigma, \eta \in G\text{-Loc } A$ be G -localized in J . We pick $\tilde{\rho}$ g -localized in $\tilde{I} < J$ and a unitary $u \in \text{Hom}(\rho, \tilde{\rho})$. Then

$$\begin{aligned} c_{\rho, \sigma} \otimes \eta &= \gamma_g(\sigma \eta)(u^*)u \\ &= \gamma_g(\sigma \eta)(u^*) \gamma_g(\sigma)(u) \gamma_g(\sigma)(u^*)u \\ &= \gamma_g(\sigma)[\gamma_g(\eta)(u^*)u] \gamma_g(\sigma)(u^*)u \\ &= \text{id}_{\gamma_g(\sigma)} \otimes c_{\rho, \eta} \circ c_{\rho, \sigma} \otimes \text{id}_\eta \end{aligned}$$

proves the braid relation (2.3).

Finally, let $\rho \in (G\text{-Loc } A)_g, \sigma \in (G\text{-Loc } A)_h$ and let $\eta \in G\text{-Loc } A$ be G -localized in J . Pick $\tilde{\rho} \in (G\text{-Loc } A)_g, \tilde{\sigma} \in (G\text{-Loc } A)_h$ G -localized in $\tilde{I} < J$ and unitaries

$u \in \text{Hom}(\rho, \tilde{\rho}), v \in \text{Hom}(\sigma, \tilde{\sigma})$. Then $w = u\rho(v) = \tilde{\rho}(\tilde{v})u \in \text{Hom}(\rho\sigma, \tilde{\rho}\tilde{\sigma})$, thus

$$\begin{aligned} c_{\rho \otimes \sigma, \eta} &= \gamma_{gh}(\eta)(w^*)w \\ &= \gamma_{gh}(\eta)(u^*\tilde{\rho}(v^*))u\rho(v) \\ &= \gamma_{gh}(\eta)(u^*)\gamma_{gh}(\eta)\tilde{\rho}(v^*)u\rho(v) \\ &= \gamma_{gh}(\eta)(u^*)\tilde{\rho}\gamma_h(\eta)(v^*)u\rho(v) \\ &= \gamma_{gh}(\eta)(u^*)u\rho[\gamma_h(\eta)(v^*)v] \\ &= \gamma_g(\gamma_h(\eta))(u^*)u\rho[\gamma_h(\eta)(v^*)v] \\ &= c_{\rho, \gamma_h(\eta)} \otimes \text{id}_\sigma \circ \text{id}_\sigma \otimes c_{\sigma, \eta}, \end{aligned}$$

where we used $\tilde{\rho}\gamma_h(\eta) = \gamma_{gh}(\eta)\tilde{\rho}$, cf. Lemma 2.14, proves (2.4). The last claim follows from $\rho_1\rho_2 = {}^{\rho_2}\rho_1\rho_2$, cf. Lemma 2.14 and the fact that we may take $\tilde{\rho} = \rho$ and $u = \text{id}_\rho$ in the definition of $c_{\rho, \sigma}$.

It remains to show the covariance (2.5) of the braiding. Recall that $c_{\rho, \sigma} \in \text{Hom}(\rho \otimes \sigma, \gamma_g(\sigma) \otimes \rho)$ was defined as $\text{id}_{\gamma_g(\sigma)} \otimes u^* \circ u \otimes \text{id}_\sigma$ for suitable u . Applying the functor γ_k we obtain

$$\begin{aligned} \text{id}_{\gamma_{k g k^{-1}}(\gamma_k(\sigma))} \otimes \gamma_k(u)^* \circ \gamma_k(u) \otimes \text{id}_{\gamma_k(\sigma)} &\in \text{Hom}(\gamma_k(\rho) \otimes \gamma_k(\sigma), \\ &\gamma_{k g k^{-1}}(\gamma_k(\sigma)) \otimes \gamma_k(\rho)), \end{aligned}$$

where $\gamma_k(u) \in \text{Hom}(\gamma_k(\rho), \gamma_k(\tilde{\rho}))$. Since this is of the same form as $c_{\gamma_k(\rho), \gamma_k(\sigma)}$ and since the braiding is independent of the choice of the intertwiner u , (2.5) follows. \square

2.3. *Semisimplicity and rigidity.* In view of Lemma 2.12 we can define

Definition 2.18. $G\text{-Loc}_f A$ is the full tensor subcategory of $G\text{-Loc } A$ of those objects ρ satisfying $[A(I) : \rho(A(I))] < \infty$ whenever ρ is g -localized in I .

The following is proven by an adaptation of the approach of [23].

Proposition 2.19. $G\text{-Loc}_f A$ is semisimple (in the sense that every object is a finite direct sum of (absolutely) simple objects). Every object of $G\text{-Loc}_f A$ has a conjugate in the sense of [36] and $G\text{-Loc}_f A$ is spherical [3].

Proof. By standard subfactor theory, $[M : \rho(M)] < \infty$ implies that the von Neumann algebra $M \cap \rho(M)' = \text{End } \rho$ is finite dimensional, thus a multi matrix algebra. This implies semisimplicity since $G\text{-Loc}_f A$ has direct sums and subobjects.

Clearly, it is sufficient to show that simple objects have conjugates, thus we consider $\rho \in (G\text{-Loc}_f A)_g$ g -localized in I . By the Reeh-Schlieder property 2.24.3, cf. e.g. [22], the vacuum Ω is cyclic and separating for every $A(I)$, $I \in \mathcal{K}$, giving rise to antilinear involutions $\mathcal{J}_I = \mathcal{J}_{(A(I), \Omega)}$ on \mathcal{H}_0 , the modular conjugations. Conditions 1-2 in Definition 2.3 imply $V(g)\mathcal{J}_I = \mathcal{J}_I V(g)$ for all $I \in \mathcal{K}$, $g \in G$. For $z \in \mathbb{R}$ and $K = (z, \infty)$ it is known [23, 22] that $j_K : x \mapsto \mathcal{J}_K x \mathcal{J}_K$ maps $A(I)$ onto $A(r_z I)$, where $r_z : \mathbb{R} \rightarrow \mathbb{R}$ is the reflection about z . Thus j_K is an antilinear involutive automorphism of A_∞ . Choosing z to be in the right hand complement of I , the geometry is as follows:

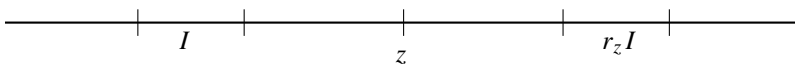

Let $\tilde{\rho}$ be g -localized in $r_z I$ and $u \in \text{Hom}(\tilde{\rho}, \rho)$ unitary. Dropping the subscript z and defining

$$\bar{\rho} = j\tilde{\rho}j\beta_g^{-1} \in \text{End}A_\infty,$$

it is clear that $\bar{\rho}$ is g^{-1} -localized in I . It is easy to see that $d(\bar{\rho}) = d(\rho)$ and that $\bar{\rho}$ is transportable, thus in $(G\text{-Loc}_f A)_{g^{-1}}$.

Now consider the subalgebras

$$A_1 = \bigcup_{\substack{I \in \mathcal{K} \\ I \subset (-\infty, z)}} A(I), \quad A_2 = \bigcup_{\substack{I \in \mathcal{K} \\ I \subset (z, \infty)}} A(I)$$

of A_∞ . We have $A'_1 = A''_2 = \mathcal{J}A''_1\mathcal{J}$. In view of $\tilde{\rho} \upharpoonright A_1 = \text{id}$ and $\rho \upharpoonright A_2 = \beta_g = \text{Ad } V(g)$ we have

$$\begin{aligned} \rho \upharpoonright A_1 &= u\tilde{\rho}(\cdot)u^* = u \cdot u^*, \\ \tilde{\rho} \upharpoonright A_2 &= u^*\rho(\cdot)u = u^*\beta_g(\cdot)u = u^*V(g) \cdot V(g)^*u. \end{aligned}$$

We therefore find

$$\rho\bar{\rho} \upharpoonright A_1 = \rho j\tilde{\rho}j\beta_g^{-1} \upharpoonright A_1 = \text{Ad } u\mathcal{J}u^*V(g)\mathcal{J}V(g)^* = \text{Ad } u\mathcal{J}u^*\mathcal{J},$$

where we used the commutativity of \mathcal{J} and $V(g)$. Since the above expressions for $\rho \upharpoonright A_1, \tilde{\rho} \upharpoonright A_2, \rho\bar{\rho} \upharpoonright A_1$ are ultraweakly continuous they uniquely extend to the weak closures A'_1, A'_2, A'_1 , respectively. Now,

$$\begin{aligned} u\mathcal{J}u^*\rho(A_1)''u\mathcal{J}u^* &= u\mathcal{J}\tilde{\rho}(A_1)''\mathcal{J}u^* = u\mathcal{J}A''_1\mathcal{J}u^* = uA''_2u^* \\ &= (uA'_2u^*)' = (uA'_1u^*)' = \rho(A'_1)' = \rho(A_1)'. \end{aligned}$$

Thus, $\tilde{\mathcal{J}} = u\mathcal{J}u^*$ is an antiunitary involution whose adjoint action maps $\rho(A_1)''$ onto $\rho(A_1)'$. Furthermore, $u\Omega$ is cyclic and separating for $\rho(A_1)''$ and we have $(u\mathcal{J}u^*)(u\Omega) = u\mathcal{J}\Omega = u\Omega$ and $(\rho(x)\tilde{\mathcal{J}}\rho(x)\tilde{\mathcal{J}}u\Omega, u\Omega) = (x\mathcal{J}x\mathcal{J}\Omega, \Omega) \geq 0 \forall x \in A'_1$. Thus $\tilde{\mathcal{J}}$ is [28, Exercise 9.6.52] the modular conjugation corresponding to the pair $(\rho(A_1)'', u\Omega)$, and therefore

$$x \mapsto \rho\bar{\rho}(x) = \mathcal{J}_{(\rho(A_1)'', u\Omega)}\mathcal{J}_{(A'_1, \Omega)}x\mathcal{J}_{(A'_1, \Omega)}\mathcal{J}_{(\rho(A_1)'', u\Omega)}$$

is a canonical endomorphism $\gamma : A'_1 \hookrightarrow \rho(A_1)''$ [34]. Since $[A'_1 : \rho(A'_1)] = [A(I) : \rho(A(I))] = d(\rho)^2$ is finite by assumption, γ contains [34] the identity morphism, to wit there is $V \in A'_1$ such that $Vx = \rho\bar{\rho}(x)V$ for all $x \in A'_1$. Since $\rho\bar{\rho}$ is (e-)localized in I , Lemma 2.13 implies $V \in A(I)$, thus the equation $Vx = \rho\bar{\rho}(x)V$ also holds for $x \in A(I')$, and strong additivity together with local normality of $\rho, \bar{\rho}$ imply that it holds for all $x \in A_\infty$. Thus $\mathbf{1} = \text{id}_{A_\infty} \prec \rho\bar{\rho}$, and $\bar{\rho}$ is a conjugate, in the sense of [36], of ρ in the tensor $*$ -category $G\text{-Loc}_f A$. Choosing a conjugate or dual $\bar{\rho}$ for every $\rho \in G\text{-Loc}_f A$ and duality morphisms $e : \bar{\rho} \otimes \rho \rightarrow \mathbf{1}, \mathbf{1} \rightarrow \rho \otimes \bar{\rho}$ satisfying the triangular equations we may consider $G\text{-Loc}_f A$ as a spherical category. \square

Remark 2.20. Every object ρ in a spherical or C^* -category with simple unit has a dimension $d(\rho)$ living in the ground field, \mathbb{C} in the present situation. This dimension of an object localized in I is related to the index by the following result of Longo [34]:

$$d(\rho) = [A(I) : \rho(A(I))]^{1/2}.$$

Summarizing the preceding discussion we have

Theorem 2.21. *G -Loc A is a braided crossed G -category and G -Loc_f A is a rigid semisimple braided crossed G -category.*

Remark 2.22. 1. It is obvious that for any braided G -crossed category \mathcal{D} , the degree zero subcategory \mathcal{D}_e is a braided tensor category. In the case at hand, $\text{Loc } A = (G\text{-Loc } A)_e$ is the familiar category of transportable localized morphisms defined in [20]. But for non-trivial symmetries G , the category $G\text{-Loc } A$ contains information that cannot be obtained from $\text{Loc } A$.

2. The closest precedent to our above considerations can be found in [54]. There, however, several restrictive assumptions were made, in particular only abelian groups G were considered. Under these assumptions the G -crossed structure essentially trivializes.

2.4. Chiral conformal QFT on S^1 . In this subsection we briefly recall the main facts pertinent to chiral conformal field theories on S^1 and their representations, focusing in particular on the completely rational models introduced and analyzed in [29]. While nothing in this subsection is new, we include the material since it will be essential in what follows.

Let \mathcal{I} be the set of intervals in S^1 , i.e. connected open non-empty and non-dense subsets of S^1 . (\mathcal{I} can be identified with the set $\{(x, y) \in S^1 \times S^1 \mid x \neq y\}$.) For every $J \subset S^1$, J' is the interior of the complement of J . This clearly defines an involution on \mathcal{I} .

Definition 2.23. *A chiral conformal field theory is a quadruple $(\mathcal{H}_0, A, U, \Omega)$, usually simply denoted by A , where*

1. \mathcal{H}_0 is a separable Hilbert space with a distinguished non-zero vector Ω .
2. A is an assignment $\mathcal{I} \ni I \mapsto A(I)$, where $A(I)$ is a von Neumann algebra on \mathcal{H}_0 .
3. U is a strongly continuous unitary representation of the Möbius group $PSU(1, 1) = SU(1, 1)/\{\mathbf{1}, -\mathbf{1}\}$, i.e. the group of those fractional linear maps $\mathbb{C} \rightarrow \mathbb{C}$ which map the circle into itself, on \mathcal{H}_0 .

These data must satisfy

- *Isotony:* $I \subset J \Rightarrow A(I) \subset A(J)$,
- *Locality:* $I \subset J' \Rightarrow A(I) \subset A(J)'$,
- *Irreducibility:* $\bigvee_{I \in \mathcal{I}} A(I) = \mathcal{B}(\mathcal{H}_0)$ (equivalently, $\bigcap_{I \in \mathcal{I}} A(I)' = \mathbb{C}\mathbf{1}$),
- *Covariance:* $U(a)A(I)U(a)^* = A(aI) \quad \forall a \in PSU(1, 1), I \in \mathcal{I}$,
- *Positive energy:* $L_0 \geq 0$, where L_0 is the generator of the rotation subgroup of $PSU(1, 1)$,
- *Vacuum:* every vector in \mathcal{H}_0 which is invariant under the action of $PSU(1, 1)$ is a multiple of Ω .

2.24. For consequences of these axioms see, e.g., [22]. We limit ourselves to listing some facts:

1. Type: The von Neumann algebra $A(I)$ is a factor of type III (in fact III₁) for every $I \in \mathcal{I}$.
2. Haag duality: $A(I)' = A(I') \quad \forall I \in \mathcal{I}$.
3. Reeh-Schlieder property: $\overline{A(I)\Omega} = \overline{A(I)'\Omega} = \mathcal{H}_0 \quad \forall I \in \mathcal{I}$.

4. The modular groups and conjugations associated with $(A(I), \Omega)$ have a geometric meaning, cf. [6, 22] for details.
5. Additivity: If $I, J \in \mathcal{I}$ are such that $I \cap J, I \cup J \in \mathcal{I}$ then $A(I) \vee A(J) = A(I \cup J)$.

In order to obtain stronger results we introduce two further axioms.

Definition 2.25. *Two intervals $I, J \in \mathcal{I}$ are called adjacent if their closures intersect in exactly one point. A chiral CFT satisfies strong additivity if*

$$I, J \text{ adjacent} \Rightarrow A(I) \vee A(J) = A(\overline{I \cup J}^0).$$

A chiral CFT satisfies the split property if the map

$$m : A(I) \otimes_{\text{alg}} A(J) \rightarrow A(I) \vee A(J), \quad x \otimes y \mapsto xy$$

extends to an isomorphism of von Neumann algebras whenever $I, J \in \mathcal{I}$ satisfy $\overline{I} \cap \overline{J} = \emptyset$.

Remark 2.26. By Möbius covariance strong additivity holds in general if it holds for one pair I, J of adjacent intervals. Furthermore, every CFT can be extended canonically to one satisfying strong additivity. The split property is implied by the property $\text{Tr} e^{-\beta L_0} < \infty \forall \beta > 0$. The latter property and strong additivity have been verified in all known rational models.

Definition 2.27. *A representation π of A on a Hilbert space \mathcal{H} is a family $\{\pi_I, I \in \mathcal{I}\}$, where π_I is a unital $*$ -representation of $A(I)$ on \mathcal{H} such that*

$$I \subset J \Rightarrow \pi_J \upharpoonright A(I) = \pi_I. \tag{2.6}$$

π is called covariant if there is a positive energy representation U_π of the universal covering group $PSU(1, 1)$ of the Möbius group on \mathcal{H} such that

$$U_\pi(a)\pi_I(x)U_\pi(a)^* = \pi_{aI}(U(a)xU(a)^*) \quad \forall a \in \widehat{PSU(1, 1)}, I \in \mathcal{I}.$$

We denote by $\text{Rep } A$ the C^* -category of all representations on separable Hilbert spaces, with bounded intertwiners as morphisms.

Definition/Proposition 2.28. *If A satisfies strong additivity and π is a representation then the Jones index of the inclusion $\pi_I(A(I)) \subset \pi_{I'}(A(I'))$ does not depend on $I \in \mathcal{I}$ and we define the dimension*

$$d(\pi) = [\pi_{I'}(A(I')) : \pi_I(A(I))]^{1/2} \in [1, \infty].$$

We define $\text{Rep}_f A$ to be the full subcategory of $\text{Rep } A$ of those representations satisfying $d(\pi) < \infty$.

As just defined, $\text{Rep } A$ and $\text{Rep}_f A$ are just C^* -categories. In order to obtain the well known result [20, 22] that the category of all (separable) representations can be equipped with braided monoidal structure, we need the following:

Proposition 2.29. *Every chiral CFT $(\mathcal{H}_0, A, U, \Omega)$ satisfying strong additivity gives rise to a QFT on \mathbb{R} .*

Proof. We arbitrarily pick a point $\infty \in S^1$ and consider

$$\mathcal{I}_\infty = \{I \in \mathcal{I} \mid \infty \notin \bar{I}\}.$$

Identifying $S^1 - \{\infty\}$ with \mathbb{R} by stereographic projection

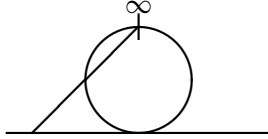

we have a bijection between \mathcal{I}_∞ and \mathcal{K} . The family $A(I), I \in \mathcal{K}$ is just the restriction of $A(I), I \in \mathcal{I}$ to $I \in \mathcal{I}_\infty \equiv \mathcal{K}$. By 2.24, A satisfies Haag duality on S^1 , and together with strong additivity (on S^1) this implies Haag duality (on \mathbb{R}) and strong additivity in the sense of Definition 2.1. \square

Remark 2.30. The definition of G -actions on a chiral CFT on S^1 is analogous to Definition 2.3, Condition 1 now being required for all $I \in \mathcal{I}$. Conditions 1-2 imply $V(g)U(a) = U(a)V(g) \forall g \in G, a \in PSU(1, 1)$. (To see this observe that 1-2 imply that $V(g)$ commutes with the modular groups associated with the pairs $(A(I), \Omega)$ for any $I \in \mathcal{I}$. By 2.24.4 the latter are one-parameter subgroups of $U(PSU(1, 1))$ which generate $U(PSU(1, 1))$.) Condition 3 now is equivalent to the more convenient axiom

3'. If $U(g) \in \mathbb{C}\mathbf{1}$ then $g = e$.

(Proof. If $U(g) \in \mathbb{C}\mathbf{1}$ then $\alpha_g = \text{id}$, thus $g = e$ by 3. Conversely, if α_g acts trivially on some $A(I)$ then $U(g)$ commutes with $A(I)$ and in fact with all $A(I)$ by $V(g)U(a) = U(a)V(g)$. Thus the irreducibility axiom implies $U(g) \in \mathbb{C}\mathbf{1}$.)

Given a CFT on S^1 and ignoring a possibly present G -action we have the categories $\text{Rep } A$ ($\text{Rep}_f A$) as well as the braided tensor categories $\text{Loc } A$ ($\text{Loc}_f A$) associated with the restriction of A to \mathbb{R} . The following result, cf. [29, Appendix], connects these categories.

Theorem 2.31. *Let $(\mathcal{H}_0, A, U, \Omega)$ be a chiral CFT satisfying strong additivity. Then there are equivalences of $*$ -categories*

$$\begin{aligned} \text{Loc } A &\simeq \text{Rep } A, \\ \text{Loc}_f A &\simeq \text{Rep}_f A, \end{aligned}$$

where $\text{Rep}_{(f)} A$ refers to the chiral CFT and Definition 2.27, whereas $\text{Loc}_{(f)} A$ refers to the QFT on \mathbb{R} obtained by restriction and Definition 2.8.

Proof. The strategy is to construct a functor $Q : \text{Loc } A \rightarrow \text{Rep } A$ of $*$ -categories and to prove that it is fully faithful and essentially surjective. Let $\rho \in \text{Loc } A$ be localized in $I \in \mathcal{K} \equiv \mathcal{I}_\infty$. Our aim is to define a representation $\pi = (\pi_I, I \in \mathcal{I})$ on the Hilbert space \mathcal{H}_0 . For every $J \in \mathcal{I}_\infty$ we define $\pi_J = \rho \upharpoonright A(J)$, considered as a representation on \mathcal{H}_0 . If $\infty \in \bar{J}$ we pick an interval $K \in \mathcal{I}_\infty, K \cap J = \emptyset$. By transportability of ρ there exists ρ' localized in K and a unitary $u \in \text{Hom}(\rho, \rho')$. Defining $\pi_J = u^* \cdot u$ we need to show that π_J is independent of the choices involved. Thus let ρ'' be localized in K (this may be assumed by making K large enough) and $v \in \text{Hom}(\rho, \rho'')$, giving rise

to $\pi'_J = v^* \cdot v$. Now, $u \circ v^* \in \text{Hom}(\rho'', \rho')$, thus $uv^* \in A(K)$ by Lemma 2.13, and therefore

$$\pi'_J(x) = v^*xv = v^*(vu^*uv^*)xv = v^*vu^*xuv^*v = u^*xu = \pi_J(x),$$

since $x \in A(J) \subset A(K)'$. Having defined π_J for all $J \in \mathcal{I}$ we need to show (2.6) for all $I, J \in \mathcal{I}$. There are three cases of inclusions $I \subset J$ to be considered: (i) $I, J \in \mathcal{I}_\infty$, (ii) $I \in \mathcal{I}_\infty, J \notin \mathcal{I}_\infty$, (iii) $I, J \notin \mathcal{I}_\infty$. Case (i) is trivial since $\pi_I = \pi_J = \rho$, restricted to $A(I), A(J)$ respectively. Case (iii) is treated by using $K \subset J'$ for the definition of both π_I, π_J and appealing to the uniqueness of the latter. In case (ii) we have $\pi_J = u^* \cdot u$ with $u \in \text{Hom}(\rho, \rho')$, ρ' localized in $K \subset J'$. For $x \in A(I)$ we have $\pi_J(x) = u^*xu = u^*\rho'(x)u = \rho(x) = \pi_I(x)$, as desired. This completes the proof of $\pi = \{\pi_J\} \in \text{Rep } A$.

Let $\rho_1, \rho_2 \in \text{Loc } A$ and let π_1, π_2 be the corresponding representations. We claim that $s \in \text{Hom}(\rho_1, \rho_2)$ implies $s \in \text{Hom}(\pi_1, \pi_2)$. Let $\infty \in \bar{J}, K \in \mathcal{I}_\infty, K \cap J = \emptyset, \rho'_i$ localized in K and $u_i \in \text{Hom}(\rho_i, \rho'_i)$ unitaries, such that then $\pi_{J,i} = u_i^* \cdot u_i$. We have $u_2su_1^* \in \text{Hom}(\rho'_1, \rho'_2)$. Since both ρ'_1, ρ'_2 are localized in K we have $u_2su_1^* \in A(K) \subset A(J)'$. Now the computation

$$s\pi_{J,1}(x) = su_1^*xu_1 = u_2^*(u_2su_1^*)xu_1 = u_2^*x(u_2su_1^*)u_1 = u_2^*xu_2s = \pi_{J,2}s$$

shows $s \in \text{Hom}(\pi_{J,1}, \pi_{J,2})$. Since this works for all J such that $\infty \in \bar{J}$ we have $s \in \text{Hom}(\pi_1, \pi_2)$, and we have defined a faithful functor $Q : \text{Loc } A \rightarrow \text{Rep } A$. Obviously, Q is faithful. In view of $\rho = \pi \upharpoonright A_\infty$ it is clear that $s \in \text{Hom}(\pi, \pi')$ implies $s \in \text{Hom}(\rho, \rho')$, thus Q is full.

Let now $\pi \in \text{Rep } A$ and $I \in \mathcal{I}$. Then π_I is a unital $*$ -representation of $A(I)$ on a separable Hilbert space. Since $A(I)$ is of type III and \mathcal{H}_0 is separable, π_I is unitarily implemented. I.e. there exists a unitary $u : \mathcal{H}_0 \rightarrow \mathcal{H}_\pi$ such that $\pi_I(x) = u x u^*$ for all $x \in A(I)$. Then $(\pi'_J) = (u^* \pi_J(\cdot) u)$ is a representation on \mathcal{H}_0 that satisfies $\pi' \cong \pi$ and $\pi'_I = \pi_{I,0} = \text{id}$. Haag duality (on S^1) implies $\pi_J(A(J)) \subset A(J)$ whenever $J \supset I'$. If we choose I such that $\infty \in I$ then $\pi_J, J \supset I'$ defines an endomorphism ρ of A_∞ whose extension to a representation $Q(\rho)$ coincides with π' . Thus Q is essentially surjective and therefore an equivalence $\text{Loc } A \simeq \text{Rep } A$.

Now, $\rho \in \text{Loc } A$ is in $\text{Loc}_f A$ iff $d(\rho) = [A(I) : \rho(A(I))]^{1/2} < \infty$ whenever ρ is localized in I . On the other hand, $\pi \in \text{Rep } A$ is in $\text{Rep}_f A$ iff $d(\pi) = [\pi_{I'}(A(I')) : \pi_I(A(I))]^{1/2} < \infty$. In view of the above construction it is clear that $d(\pi) = d(\rho)$ if π is the representation corresponding to ρ . Thus Q restricts to an equivalence $\text{Loc}_f A \simeq \text{Rep}_f A$. \square

Using the equivalence Q the braided monoidal structure of $\text{Loc}_{(f)} A$ can be transported to $\text{Rep}_{(f)} A$:

Corollary 2.32. *Rep A ($\text{Rep}_f A$) can be equipped with a (rigid) braided monoidal structure such that there are equivalences*

$$\begin{aligned} \text{Loc } A &\simeq \text{Rep } A, \\ \text{Loc}_f A &\simeq \text{Rep}_f A \end{aligned}$$

of braided monoidal categories.

Remark 2.33. 1. It is quite obvious that the braided tensor structure on $\text{Rep } A$ provided by the above constructions is independent, up to equivalence, of the choice of the point $\infty \in S^1$. For an approach to the representation theory of QFTs on S^1 that does not rely on cutting the circle see [21]. The latter, however, seems less suited for the analysis of $G\text{-Loc } A$ for non-trivial G since the g -localized endomorphisms of A_∞ do not extend to endomorphisms of the global algebra $\mathcal{A}_{\text{univ}}$ of [21] if $g \neq e$.

2. Given a chiral CFT A , the category $\text{Rep } A$ is a very natural object to consider. Thus the significance of the degree zero category $(G\text{-Loc } A)_e$ is plainly evident: It enables us to endow $\text{Rep } A$ with a braided monoidal structure in a considerably easier way than any known alternative.

3. By contrast, the rest of the category $G\text{-Loc } A$ has no immediate physical interpretation. After all, the objects of $(G\text{-Loc}_f A)_g$ with $g \neq e$ do not represent proper representations of A since they ‘behave discontinuously at ∞ ’. In fact, it is not difficult to prove that, given two adjacent intervals $I, J \in \mathcal{I}$ and $g \neq e$, there exists no representation π of A such that $\pi \upharpoonright A(I) = \text{id}$ and $\pi \upharpoonright A(J) = \beta_g$. Thus ρ , considered as a representation of A_∞ , cannot be extended to a representation of A . The main *physical* relevance of $G\text{-Loc}_f A$ is that – in contradistinction to $\text{Rep}_f A$ – it contains sufficient information to compute $\text{Rep}_f A^G$. This will be discussed in the next section.

4. On the purely *mathematical* side, the category $G\text{-Loc } A$ may be used to define an invariant of three dimensional G -manifolds [60], i.e. 3-manifolds equipped with a principal G -bundle. As mentioned in the introduction, this provides an equivariant version of the construction of a 3-manifold invariant from a rational CFT.

As is well known, there are models, like the $U(1)$ current algebra, that satisfy the standard axioms including strong additivity and the split property and that have infinitely many inequivalent irreducible representations. Since in this work we are mainly interested in rational CFTs we need another axiom to single out the latter.

Definition/Proposition 2.34. [29]. *Let A satisfy strong additivity and the split property. Let $I, J \in \mathcal{I}$ satisfy $\bar{I} \cap \bar{J} = \emptyset$ and write $E = I \cup J$. Then the index of the inclusion $A(E) \subset A(E)'$ does not depend on I, J and we define*

$$\mu(A) = [A(E)' : A(E)] \in [1, \infty].$$

A chiral CFT on S^1 is completely rational if it satisfies (a) strong additivity, (b) the split property and (c) $\mu(A) < \infty$.

Remark 2.35. 1. Thus every CFT satisfying strong additivity and the split property comes along with a numerical invariant $\mu(A) \in [1, \infty]$. The models where the latter is finite – the completely rational ones – are among the best behaved (non-trivial) quantum field theories, in that very strong results on both their structure and representation theory have been proven in [29]. In particular the invariant $\mu(A)$ has a nice interpretation.

2. All known classes of rational CFTs are completely rational in the above sense. For the WZW models connected to loop groups this is proven in [61, 63]. More importantly, the class of completely rational models is stable under tensor products and finite extensions and subtheories, cf. Sect. 3 for more details. This has applications to orbifold and coset models.

Theorem 2.36. [29]. *Let A be a completely rational CFT. Then*

- *Every representation of A on a separable Hilbert space is completely reducible, i.e. a direct sum of irreducible representations. (For non-separable representations this*

is also true if one assumes local normality, which is automatic in the separable case, or equivalently covariance.)

- Every irreducible separable representation has finite dimension $d(\pi)$, thus $\text{Rep}_f A$ is just the category of finite direct sums of irreducible representations.
- The number of unitary equivalence classes of separable irreducible representations is finite and

$$\dim \text{Rep}_f A = \mu(A),$$

where $\dim \text{Rep}_f A$ is the sum of the squared dimensions of the simple objects.

- The braiding of $\text{Loc}_f A \simeq \text{Rep}_f A$ is non-degenerate, thus $\text{Rep}_f A$ is a unitary modular category in the sense of Turaev [59].

3. Orbifold Theories and Galois Extensions

3.1. The restriction functor $R : (G - \text{Loc} A)^G \rightarrow \text{Loc} A^G$. After the interlude of the preceding subsection we now return to QFTs defined on \mathbb{R} with symmetry G . (Typically they will be obtained from chiral CFTs on S^1 by restriction, but in the first subsections this will not be assumed.) Our aim is to elucidate the relationship between the categories $G - \text{Loc} A$ and $\text{Loc} A^G$, where A^G is the ‘orbifold’ subtheory of G -fixpoints in the theory A .

Definition 3.1. Let (\mathcal{H}, A, Ω) be a QFT on \mathbb{R} with an action (in the sense of Definition 2.3) of a compact group G . Let \mathcal{H}_0^G and $A(I)^G$ be the fixpoints under the G -action on \mathcal{H}_0 and $A(I)$, respectively. Then the orbifold theory A^G is the triple $(\mathcal{H}_0^G, A^G, \Omega)$, where $A^G(I) = A(I)^G \upharpoonright \mathcal{H}_0^G$.

Remark 3.2. 1. The definition relies on $\Omega \in \mathcal{H}_0^G$ and $A(I)^G \mathcal{H}_0^G \subset \mathcal{H}_0^G$ for all $I \in \mathcal{K}$. Denoting by p the projector onto \mathcal{H}_0^G , we have $A^G(I) = A(I)^G \upharpoonright \mathcal{H}_0^G = pA(I)p$, where the right hand side is understood as an algebra acting on $p\mathcal{H}_0 = \mathcal{H}_0^G$. Furthermore, since $A(I)^G$ acts faithfully on \mathcal{H}_0^G we have algebra isomorphisms $A(I)^G \cong A^G(I)$.

2. It is obvious that the triple $(\mathcal{H}_0^G, A^G, \Omega)$ satisfies isotony and locality. Irreducibility follows by $\bigvee_{I \in \mathcal{K}} A^G(I) = p(\bigvee_{I \in \mathcal{K}} A(I))p$ together with $\bigvee_I A(I) = \mathcal{B}(\mathcal{H}_0)$. However, strong additivity and Haag duality of the fixpoint theory are not automatic. For the time being we will postulate these properties to hold. Later on we will restrict to settings where this is automatically the case.

3.3. For later purposes we recall a well known fact about compact group actions on QFTs in the present setting. Namely, for every $I \in \mathcal{K}$, the G -action on $A(I)$ has full \widehat{G} -spectrum, [15]. This means that for every isomorphism class $\alpha \in \widehat{G}$ of irreducible representations of G there exists a finite dimensional G -stable subspace $V_\alpha \subset A(I)$ on which the G -action restricts to the irrep π_α . V_α can be taken to be a space of isometries of support 1. (This means that V_α admits a basis $\{v_\alpha^i, i = 1, \dots, d_\alpha\}$ such that $\sum_i v_\alpha^i v_\alpha^{i*} = \mathbf{1}$ and $v_\alpha^{i*} v_\alpha^j = \delta_{ij} \mathbf{1}$.) Furthermore, $A(I)$ is generated by $A(I)^G$ and the spaces $V_\alpha, \alpha \in \widehat{G}$.

These observations have an important consequence for the representation categories of fixpoint theories [15]. Namely the category $\text{Loc}_f A^G$ contains a full symmetric subcategory \mathcal{S} equivalent to the category $\text{Rep}_f G$ of finite dimensional continuous unitary representations of G . The objects in \mathcal{S} are given by the localized endomorphisms of A_∞^G

of the form $\rho_\alpha(\cdot) = \sum_i v_\alpha^i \cdot v_\alpha^{i*}$, where $\{v_\alpha^i\}$ is a space of isometries with support $\mathbf{1}$ in $A(I)$ transforming under the irrep $\alpha \in \widehat{G}$. (Equivalently, a simple object of $\rho \in \text{Loc}_f A^G$ is in \mathcal{S} iff the corresponding representation $\pi_0 \circ \rho$ of A^G is contained in the restriction to A^G of the defining (or vacuum) representation of A .)

3.4. We now begin our study of the relationship between $G\text{-Loc}A$ and $\text{Loc}A^G$. Let $(G\text{-Loc}A)^G$ denote the G -invariant objects and morphisms of $G\text{-Loc}A$. By definition of the G -action on $G\text{-Loc}A$, $\rho \in (G\text{-Loc}A)^G$ implies $\rho \circ \beta_g = \beta_g \circ \rho$ for all $g \in G$, thus $\rho(A_\infty^G) \subset A_\infty^G$. Every $\rho \in G\text{-Loc}A$ is G -localized in some interval I . In view of Definition 2.8 it is obvious that the restriction $\rho \upharpoonright A_\infty^G$ acts trivially on $A(J)$ not only if $J < I$, but also if $J > I$. Thus $\rho \upharpoonright A_\infty^G$ is a localized endomorphism of A_∞^G . Furthermore, if $\rho, \sigma \in (G\text{-Loc}A)^G$ and $s \in \text{Hom}_{(G\text{-Loc}A)^G}(\rho, \sigma)$ it is easy to see that $s \in \text{Hom}_{\text{Loc}A^G}(\rho \upharpoonright A_\infty^G, \sigma \upharpoonright A_\infty^G)$. This suggests that $\rho \upharpoonright A_\infty^G \in \text{Loc}A^G$. However, this also requires showing that the restricted morphism $\rho \upharpoonright A_\infty^G$ is transportable by morphisms in $\text{Loc}A^G$. This requires some work.

Proposition 3.5. *Let $\rho \in (G\text{-Loc}A)^G$. Then $\rho \upharpoonright A_\infty^G \in \text{Loc}A^G$.*

Proof. By definition, ρ is G -localized in some interval I . As we have seen in 3.4, $\rho \upharpoonright A_\infty^G$ is localized in I , and it remains to show that $\rho \upharpoonright A_\infty^G$ is transportable. Let thus J be another interval. By transportability of $\rho \in G\text{-Loc}A$, there exists $\tilde{\rho}$ that is G -localized in J and a unitary $u \in \text{Hom}_{G\text{-Loc}A}(\rho, \tilde{\rho})$. Define $\tilde{\rho}_g = \gamma_g(\tilde{\rho}) = \beta_g \circ \tilde{\rho} \circ \beta_g^{-1}$. Since γ_g is an automorphism of $G\text{-Loc}A$ and ρ is G -invariant we have $\gamma_g(u) := \beta_g(u) \in \text{Hom}_{G\text{-Loc}A}(\rho, \tilde{\rho}_g)$. Defining $v_g = \beta_g(u)u^*$ we have

$$v_{gh} = \beta_{gh}(u)u^* = \beta_g(v_h)\beta_g(u)u^* = \beta_g(v_h)v_g \quad \forall g, h.$$

Furthermore, $v_g \in \text{Hom}(\tilde{\rho}, \tilde{\rho}_g)$, and since all $\tilde{\rho}_g$ are G -localized in J , Lemma 2.13 implies $v_g \in A(J)$. Thus $g \mapsto v_g$ is a (strongly continuous) 1-cocycle in $A(J)$. Since $A(J)$ is a type III factor and the G -action has full \widehat{G} -spectrum, there exists [57] a unitary $w \in A(J)$ such that $v_g = \beta_g(w)w^*$ for all $g \in G$. Defining $\widehat{\rho} = \text{Ad } w^* \circ \tilde{\rho}$, we have $w^*u \in \text{Hom}(\rho, \widehat{\rho})$. Now, $\beta_g(u)u^* = \beta_g(w)w^*$ is equivalent to $\beta_g(w^*u) = w^*u$, thus w^*u is G -invariant. Together with the obvious fact that $\widehat{\rho}$ is G -localized in J , this implies $\rho \upharpoonright A_\infty^G \in \text{Loc}A^G$. \square

Corollary 3.6. *Restriction to A_∞^G provides a strict tensor functor $R : (G\text{-Loc}A)^G \rightarrow \text{Loc}A^G$ which is faithful on objects and morphisms.*

Proof. With the exception of faithfulness, which follows from the isomorphisms $A(I)^G \cong A^G(I)$, this is just a restatement of our previous results. \square

Remark 3.7. 1. In Subsect. 3.4 we will show that R , when restricted to $(G\text{-Loc}_f A)^G$, is also surjective on morphisms (thus full) and objects. Thus R will establish an isomorphism $(G\text{-Loc}_f A)^G \cong \text{Loc}_f A^G$.

2. We comment on our definition of the fixpoint category \mathcal{C}^G of a category \mathcal{C} under a G -action. In the literature, cf. [58, 30, 31], one can find a different notion of fixpoint category, which we denote by \mathcal{C}_G for the present purposes. Its objects are pairs $(X, \{u_g, g \in G\})$, where X is an object of \mathcal{C} and the $u_g \in \text{Hom}_{\mathcal{C}}(X, \gamma_g(X))$ are isomorphisms making the left diagram in Fig. 1 commute. The morphisms between $(X, \{u_g, g \in G\})$ and $(Y, \{v_g, g \in G\})$ are those $s \in \text{Hom}_{\mathcal{C}}(X, Y)$ for which the right diagram in Fig. 1

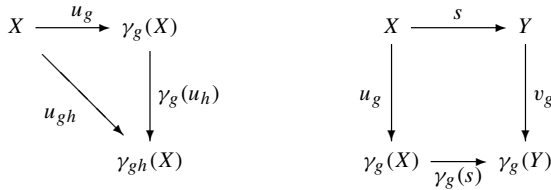

Fig. 1. Objects and Morphisms of \mathcal{C}_G

commutes. (According to J. Bernstein, \mathcal{C}_G should rather be called the category of G -modules in \mathcal{C} .) It is clear that \mathcal{C}^G can be identified with a full subcategory of \mathcal{C}_G via $X \mapsto (X, \{\text{id}\})$, but in general this inclusion need not be an equivalence. However, it is an equivalence in the case of $\mathcal{C} = G\text{-LocA}$. To see this, let $(\rho, \{u_g\}) \in (G\text{-LocA})_G$. Assume ρ is G -localized in I . By definition of $(G\text{-LocA})_G$, $g \mapsto u_g$ is a 1-cocycle in $A(I)$, and by the above discussion there exists $w \in A(I)$ such that $u_g = \beta_g(w)w^*$ for all $g \in G$. Defining $\tilde{\rho} = \text{Ad } w^* \circ \rho$, an easy computation shows $\tilde{\rho} \in (G\text{-LocA})^G$. Since $w : \tilde{\rho} \rightarrow \rho$ is an isomorphism, the inclusion $(G\text{-LocA})^G \hookrightarrow (G\text{-LocA})_G$ is essentially surjective, thus an equivalence.

3.2. *The extension functor* $E : \text{LocA}^G \rightarrow (G\text{-LocA})^G$. In view of Remark 3.2 we are in a setting where both $A = (\mathcal{H}_0, A(\cdot), \Omega)$ and $A^G = (\mathcal{H}_0^G, A^G(\cdot), \Omega)$ are QFTs on \mathbb{R} . In this situation it is well known that there exists a monoidal functor $E : \text{Loc } A^G \rightarrow \text{End } A_\infty$ from the tensor category of localized transportable endomorphisms of the subtheory A^G to the (not a priori localized) endomorphisms of the algebra A_∞ . There are essentially three ways to construct such a functor. First, Roberts’ method of localized cocycles, cf. e.g. [55], which is applicable under the weakest set of assumptions. (Neither finiteness of the extension nor factoriality or Haag duality are required.) Unfortunately, in this approach it is relatively difficult to make concrete computations, cf. however [8]. Secondly, the subfactor approach of Longo and Rehren [35] as further studied by Xu, Böckenhauer and Evans, cf. e.g. [62, 4]. This approach requires factoriality of the local algebras and finiteness of the extension, but otherwise is very powerful. Thirdly, there is the approach of [42], which assumes neither factoriality nor finiteness, but which is restricted to extensions of the form $A^G \subset A$. For the present purposes, this is of course no problem.

Theorem 3.8. [42]. *Let $A = (\mathcal{H}_0, A(\cdot), \Omega)$ be a QFT on \mathbb{R} with G -action such that $A^G = (\mathcal{H}_0^G, A^G(\cdot), \Omega)$ is a QFT on \mathbb{R} . There is a functor $E : \text{Loc } A^G \rightarrow \text{End } A_\infty$ with the following properties:*

1. *For every $\rho \in \text{Loc } A^G$ we have that $E(\rho)$ commutes with the G -action β , i.e. $E(\rho) \in (\text{End } A_\infty)^G$. The restriction $E(\rho) \upharpoonright A_\infty^G$ coincides with ρ . On the arrows, E is the inclusion $A_\infty^G \hookrightarrow A_\infty$. Thus E is faithful and injective on the objects.*
2. *E is strict monoidal. (Recall that $\text{Loc } A^G$ and $\text{End } A_\infty$ are strict.)*
3. *If ρ is localized in the interval $I \in \mathcal{K}$ then $E(\rho)$ is localized in the half-line $(\inf I, +\infty)$. This requirement makes $E(\rho)$ unique.*

Remarks on the proof. Fix an interval $I \in \mathcal{K}$. By 3.3, we can find a family $\{V_\alpha \subset A(I), \alpha \in \widehat{G}\}$ of finite dimensional subspaces of isometries of support 1 on which the

G -action restricts to the irreducible representation $\alpha \in \widehat{G}$. Now the algebra $A(I)$ is generated by $A(I)^G$ and the family $\{V_\alpha, \alpha \in \widehat{G}\}$, and A_∞ is generated by A_∞^G and the family $\{V_\alpha, \alpha \in \widehat{G}\}$. Furthermore, $\sigma_\alpha = \sum_i v_\alpha^i \cdot v_\alpha^{i*}$ is a transportable endomorphism of A_∞^G localized in I , thus $\sigma_\alpha \in \text{Loc}_f A^G$. Now $E(\rho)$ is determined by Rehren’s prescription [53]:

$$E(\rho)(x) = \begin{cases} \rho(x) & x \in A_\infty^G \\ c(\sigma_\alpha, \rho)x & x \in V_\alpha, \end{cases}$$

where $c(\sigma_\alpha, \rho)$ is the braiding of the category $\text{Loc } A^G$. (The proof of existence and uniqueness of $E(\rho)$ is given in [42], generalizing the automorphism case treated in [17]. Note that despite the appearances this definition of E does not depend on the chosen spaces V_α .) On the arrows $\text{Hom}_{\text{Loc } A^G}(\rho, \sigma) \subset A_\infty^G$ we define E via the inclusion $A_\infty^G \hookrightarrow A_\infty$. For the verification of all claimed properties see [42, Prop. 3.11]. \square

Remark 3.9. 1. The definition of E does not require $d(\rho) < \infty$. But from now on we will restrict E to the full subcategory $\text{Loc}_f A^G \subset \text{Loc } A^G$.

2. The extension functor E is faithful but not full. Our aim will be to compute $\text{Hom}_{\text{End } A_\infty}(E(\rho), E(\sigma))$, but this will require some categorical preparations.

3.3. Recollections on Galois extensions of braided tensor categories. From the discussion in 3.3 it is clear that the extension $E(\rho) \in \text{End } A_\infty$ is trivial, i.e. isomorphic to a direct sum of $\dim(\rho) \in \mathbb{N}$ copies of the tensor unit $\mathbf{1}$, for every ρ in the full symmetric subcategory \mathcal{S} . It is therefore natural to ask for the universal faithful tensor functor $\iota : \mathcal{C} \rightarrow \mathcal{D}$ that trivializes a full symmetric subcategory \mathcal{S} of a rigid braided tensor category \mathcal{C} . Such a functor has been constructed independently in [44] (without explicit discussion of the universal property) and in [5]. (The motivation of both works was to construct a modular category from a non-modular braided category by getting rid of the central/degenerate/transparent objects.) A universal functor $\iota : \mathcal{C} \rightarrow \mathcal{D}$ trivializing \mathcal{S} exists provided every object in \mathcal{S} has trivial twist $\theta(X)$, both approaches relying on the fact [18, 9] that under this condition \mathcal{S} is equivalent to the representation category of a group G , which is finite if \mathcal{S} is finite and otherwise compact [18] or proalgebraic [9]. In the subsequent discussion we will use the approach of [44] since it was set up with the present application in mind, but we will phrase it in the more conceptual way expounded in [48].

Given a rigid symmetric tensor $*$ -category \mathcal{S} with simple unit and trivial twists, the main result of [18] tells us that there is a compact group G such that $\mathcal{S} \simeq \text{Rep}_f G$. (In our application to the subcategory $\mathcal{S} \subset \text{Loc}_f A^G$ for an orbifold CFT A^G we don’t need to appeal to the reconstruction theorem since the equivalence $\mathcal{S} \simeq \text{Rep}_f G$ is proven already in [15].) Assuming \mathcal{S} (and thus G) to be finite we know that there is a commutative strongly separable Frobenius algebra $(\gamma, m, \eta, \Delta, \varepsilon)$ in \mathcal{S} , where γ corresponds to the left regular representation of G under the equivalence. See [46] for the precise definition and proofs. (More generally, this holds for any finite dimensional semisimple and cosemisimple Hopf algebra H [46]. For infinite compact groups and infinite dimensional discrete quantum groups one still has an algebra structure (γ, m, η) , cf. [50].) The group G can be recovered from the monoid structure (γ, m, η) as

$$G \cong \{s \in \text{End } \gamma \mid s \circ m = m \circ s \otimes s, s \circ \eta = \eta\}.$$

Now we define [48] a category $\mathcal{C} \rtimes_0 \mathcal{S}$ with the same objects and same tensor product of objects as \mathcal{C} , but larger hom-sets:

$$\text{Hom}_{\mathcal{C} \rtimes_0 \mathcal{S}}(\rho, \sigma) = \text{Hom}_{\mathcal{C}}(\gamma \otimes \rho, \sigma).$$

The compositions \circ, \otimes of morphisms are defined using the Frobenius algebra structure on γ . Finally, $\mathcal{C} \rtimes \mathcal{S}$ is defined as the idempotent completion (or Karoubian envelope) of $\mathcal{C} \rtimes_0 \mathcal{S}$. The latter contains $\mathcal{C} \rtimes_0 \mathcal{S}$ as a full subcategory and is unique up to equivalence, but there also is a well known canonical model for it. I.e., the objects of $\mathcal{C} \rtimes \mathcal{S}$ are pairs (ρ, p) , where $\rho \in \mathcal{C} \rtimes_0 \mathcal{S}$ and $p = p^2 = p^* \in \text{End}_{\mathcal{C} \rtimes_0 \mathcal{S}}(\rho)$. The morphisms are given by

$$\begin{aligned} \text{Hom}_{\mathcal{C} \rtimes \mathcal{S}}((\rho, p), (\sigma, q)) &= q \circ \text{Hom}_{\mathcal{C} \rtimes_0 \mathcal{S}}(\rho, \sigma) \circ q \\ &= \{s \in \text{Hom}_{\mathcal{C} \rtimes_0 \mathcal{S}}(\rho, \sigma) \mid s = q \circ s \circ p\}. \end{aligned}$$

The inclusion functor $\iota : \mathcal{C} \rightarrow \mathcal{C} \rtimes \mathcal{S}$, $\rho \mapsto (\rho, \text{id}_\rho)$ has the desired trivialization property since $\dim \text{Hom}_{\mathcal{C} \rtimes \mathcal{S}}(\mathbf{1}, \iota(\rho)) = d(\rho)$ for all $\rho \in \mathcal{S}$. The group G acts on a morphism $s \in \text{Hom}_{\mathcal{C} \rtimes \mathcal{S}}((\rho, p), (\sigma, q)) \subset \text{Hom}_{\mathcal{C}}(\gamma \otimes \rho, \sigma)$ via $\gamma_g(s) = s \circ g^{-1} \otimes \text{id}_\rho$, where $g \in \text{Aut}(\gamma, m, \eta) \cong G$. The G -fixed subcategory $(\mathcal{C} \rtimes \mathcal{S})^G$ is just the idempotent completion of \mathcal{C} and thus equivalent to \mathcal{C} . The braiding c of \mathcal{C} lifts to a braiding of $\mathcal{C} \rtimes \mathcal{S}$ iff all objects of \mathcal{S} are central, i.e. $c(\rho, \sigma)c(\sigma, \rho) = \text{id}$ for all $\rho \in \mathcal{S}$ and $\sigma \in \mathcal{C}$. This, however, will not be the case in the application to QFT. As shown in [48], in the general case $\mathcal{C} \rtimes \mathcal{S}$ is a braided crossed G -category. We need one concrete formula from [48]. Namely, if $p \in \text{End}_{\mathcal{C} \rtimes \mathcal{S}}(\rho) \cong \text{Hom}_{\mathcal{C}}(\gamma \otimes \rho, \rho)$ is such that $(\rho, p) \in \mathcal{C} \rtimes \mathcal{S}$ is simple, then the morphism

$$\partial(\rho, p) = \left(\begin{array}{c} \text{---} \\ \text{---} \\ \boxed{p} \\ \text{---} \\ \text{---} \\ \text{---} \\ \circ \\ \eta \end{array} \right)^{-1} \cdot \begin{array}{c} \gamma \\ \diagdown \quad \diagup \\ \diagup \quad \diagdown \\ \text{---} \\ \Delta \\ \text{---} \\ \boxed{p} \\ \text{---} \\ \rho \\ \text{---} \\ \gamma \end{array} \quad (3.1)$$

is an automorphism of the monoid (γ, m, η) , thus an element of G . We note for later use that the numerical factor $(\dots)^{-1}$ is $d(\rho, p)^{-1}$ and that replacing the braidings by their

duals $(\begin{array}{c} \diagdown \quad \diagup \\ \diagup \quad \diagdown \end{array} \leftrightarrow \begin{array}{c} \diagup \quad \diagdown \\ \diagdown \quad \diagup \end{array})$ gives the inverse group element.

If the category \mathcal{S} , equivalently the group G are infinite, the above definition of $\mathcal{C} \rtimes \mathcal{S}$ needs to be reconsidered since, e.g., the proof of semisimplicity must be modified. The original construction of $\mathcal{C} \rtimes \mathcal{S}$ in [44] does just that. Using the decomposition $\gamma \cong \bigoplus_{i \in \widehat{G}} d(\gamma_i) \gamma_i$ of the regular representation one defines

$$\text{Hom}_{\mathcal{C} \rtimes_0 \mathcal{S}}(\rho, \sigma) = \bigoplus_{i \in \widehat{G}} \text{Hom}_{\mathcal{C}}(\gamma_i \otimes \rho, \sigma) \otimes \mathcal{H}_i, \quad (3.2)$$

where $F : \mathcal{S} \rightarrow \text{Rep}_f G$ is an equivalence, $\gamma_i \in \mathcal{S}$ is such that $F(\gamma_i) \cong \pi_i$ and H_i is the representation space of the irreducible representation π_i of G . (It is easily seen that $\text{Hom}_{\mathcal{C} \rtimes_0 \mathcal{S}}(\rho, \sigma)$ is finite dimensional for all $\rho, \sigma \in \mathcal{C}$.) Now the compositions \circ, \otimes of morphisms are defined by the formulae

$$s \boxtimes \psi_k \circ t \boxtimes \psi_l = \bigoplus_{m \in \widehat{G}} \sum_{\alpha=1}^{N_{kl}^m} s \circ \text{id}_{\gamma_k} \otimes t \circ w_{kl}^{m\alpha} \otimes \text{id}_\rho \boxtimes K(w_{kl}^{m\alpha})^*(\psi_k \otimes \psi_l),$$

$$u \boxtimes \psi_k \otimes w \boxtimes \psi_l = \bigoplus_{m \in \widehat{G}} \sum_{\alpha=1}^{N_{kl}^m} u \otimes v \circ \text{id}_{\gamma_k} \otimes \varepsilon(\gamma_l, \rho_1) \otimes \text{id}_{\rho_2} \circ w_{kl}^{m\alpha} \otimes \text{id}_{\rho_1 \rho_2} \boxtimes K(w_{kl}^{m\alpha})^*(\psi_k \otimes \psi_l),$$

where $k, l \in \widehat{G}$, $\psi_k \in \mathcal{H}_k$, $\psi_l \in \mathcal{H}_l$, $t \in \text{Hom}(\gamma_l \otimes \rho, \sigma)$, $s \in \text{Hom}(\gamma_k \otimes \sigma, \delta)$ and $u \in \text{Hom}(\gamma_k \otimes \rho_1, \sigma_1)$, $v \in \text{Hom}(\gamma_l \otimes \rho_2, \sigma_2)$. For further details and the definition of the $*$ -involution, which we don't need here, we refer to [44]. For finite G it is readily verified that the two definitions of $\mathcal{C} \rtimes \mathcal{S}$ given above produce isomorphic categories. If Γ is central in \mathcal{C} , equivalently $c(\rho, \sigma)c(\sigma, \rho) = \text{id}$ for all $\rho \in \mathcal{S}, \sigma \in \mathcal{C}$, then $\mathcal{C} \rtimes \mathcal{S}$ inherits the braiding of \mathcal{C} , cf. [44]. If this is not the case, $\Gamma - \text{Mod}$ is only a braided crossed G -category [48].

Before we return to our quantum field theoretic considerations we briefly comment on the approach of [5] and the related works [52, 32, 30, 31]. As before, one starts from the (Frobenius) algebra in \mathcal{S} corresponding to the left regular representation of G . One now considers the category $\Gamma - \text{Mod}$ of left modules over this algebra. As already observed in [52], this is a tensor category. Again, if Γ is central in \mathcal{C} then $\Gamma - \text{Mod}$ is braided [5], whereas in general $\Gamma - \text{Mod}$ is a braided crossed G -category [30, 31]. (The braided degree zero subcategory coincides with the dyslexic modules of [52].) In [48] an equivalence of $\mathcal{C} \rtimes \mathcal{S}$ and $\Gamma - \text{Mod}$ is proven. In the present investigations it is more convenient to work with $\mathcal{C} \rtimes \mathcal{S}$ since it is strict if \mathcal{C} is.

3.4. The isomorphism $\text{Loc}_f A^G \cong (G\text{-Loc}_f A)^G$. In Subsect. 3.2, the extension functor E was defined on the entire category $\text{Loc}_f A^G$. It is faithful but not full, and our aim is to obtain a better understanding of $\text{Hom}_{A_\infty}(E(\rho), E(\sigma))$. From now on we will restrict it to the full subcategory $\text{Loc}_f A^G$ of finite dimensional (thus rigid) objects, and we abbreviate $\mathcal{C} = \text{Loc}_f A^G$ throughout. Furthermore, $\mathcal{S} \subset \mathcal{C}$ will denote the full subcategory discussed in 3.3. We recall that $\mathcal{S} \simeq \text{Rep}_f G$ as symmetric tensor category. Since the definition of $\mathcal{C} \rtimes \mathcal{S}$ in [44] was motivated by the formulae [53, 42] for the intertwiner spaces $\text{Hom}_{A_\infty}(E(\rho), E(\sigma))$, the following is essentially obvious:

Proposition 3.10. *Under the same assumptions on A and A^G and notation as above, the functor $E : \mathcal{C} \rightarrow (\text{End } A_\infty)^G$ factors through the canonical inclusion functor $\iota : \mathcal{C} \hookrightarrow \mathcal{C} \rtimes \mathcal{S}$, i.e. there is a tensor functor $F : \mathcal{C} \rtimes \mathcal{S} \rightarrow \text{End } A_\infty$ such that*

$$\begin{array}{ccc} \mathcal{C} & \xrightarrow{\iota} & \mathcal{C} \rtimes \mathcal{S} \\ & \searrow E & \downarrow F \\ & & \text{End } A_\infty \end{array}$$

commutes. (Note that $F(\mathcal{C} \rtimes \mathcal{S}) \not\subset (\text{End } A_\infty)^G$.) The functors

$$\begin{aligned} E &: \mathcal{C} &\rightarrow (\text{End } A_\infty)^G, \\ F &: \mathcal{C} \rtimes \mathcal{S} &\rightarrow \text{End } A_\infty \end{aligned}$$

are faithful and full.

Proof. First, we define F on the tensor category $\mathcal{C} \rtimes_0 \mathcal{S}$ of [44, 48], which has the same objects as \mathcal{C} but larger hom-sets. We clearly have to put $F(\rho) := E(\rho)$. Now fix an interval $I \in \mathcal{K}$ and subspaces $H_i \subset A(I)$ of isometries on which G acts according to the irrep π_i . Let γ_i be the endomorphism of A_∞^G implemented by H_i . As stated in [53] and proven in [42], the intertwiner spaces between extensions $E(\rho), E(\sigma)$ is given by

$$\text{Hom}_{A_\infty}(E(\rho), E(\sigma)) = \text{span}_{i \in \widehat{G}} \text{Hom}_{\mathcal{C}}(\gamma_i \rho, \sigma) H_i \subset A_\infty.$$

On the one hand, this shows that every G -invariant morphism $s \in \text{Hom}_{G\text{-Loc}_f A}(E(\rho), E(\sigma))$ is in $\text{Hom}_{\text{Loc}_f A^G}(\rho, \sigma)$, implying that $E : \mathcal{C} \rightarrow (\text{End } A_\infty)^G$ is full. On the other hand, it is clear that these spaces can be identified with those in the second definition (3.2) of $\text{Hom}_{\mathcal{C} \rtimes_0 \mathcal{S}}(\rho, \sigma)$. Under this identification, the compositions \circ, \otimes of morphisms in $\mathcal{C} \rtimes_0 \mathcal{S}$ go into those in the category $\text{End } A_\infty$ as given in Definition 2.5, as is readily verified. Thus we have a full and faithful strict tensor functor $F_0 : \mathcal{C} \rtimes_0 \mathcal{S} \rightarrow \text{End } A_\infty$ such that $F_0 \circ \iota = E$. Now, $\mathcal{C} \rtimes \mathcal{S}$ is defined as the completion of $\mathcal{C} \rtimes_0 \mathcal{S}$ with splitting idempotents. Since the category $\text{End } A_\infty$ has splitting idempotents, the functor F_0 extends to a tensor functor $F : \mathcal{C} \rtimes \mathcal{S} \rightarrow \text{End } A_\infty$, uniquely up to natural isomorphism of functors. However, we give a more concrete prescription. Let (ρ, p) be an object of $\mathcal{C} \rtimes \mathcal{S}$, i.e. $\rho \in \text{Loc}_f A$ and $p = p^2 = p^* \in \text{End}_{\mathcal{C} \rtimes_0 \mathcal{S}}(\rho)$. Let $I \subset \mathcal{K}$ be an interval in which $\rho \in \text{Loc}_f A$ is localized. Then Haag duality implies $p \in A(I)$. Since $A(I)$ is a type III factor (with separable preduel) we can pick $v \in A(I)$ such that $vv^* = p$ and $v^*v = 1$. Now we define $F((\rho, p))(\cdot) = v^*F(\rho)(\cdot)v \in \text{End } A_\infty$. This is an algebra endomorphism of A_∞ since $vv^* = p \in \text{Hom}_{A_\infty}(E(\rho), E(\rho))$. With this definition, the functor $F : \mathcal{C} \rtimes \mathcal{S} \rightarrow \text{End } A_\infty$ is strongly (but not strictly) monoidal. \square

In [48] it was shown that $\mathcal{C} \rtimes \mathcal{S}$ is a braided crossed G -category. In view of the results of Sect. 2 it is natural to expect that the functor F actually takes its image in $G\text{-Loc}_f A$ and is a functor of braided crossed G -categories. In fact:

Proposition 3.11. *Let $A = (\mathcal{H}_0, A(\cdot), \Omega)$ be as before and G finite. Then*

(i) *for every $\rho \in \text{Loc}_f A^G$ we have $E(\rho) \in G\text{-Loc}_f A$, thus the extension $E(\rho)$ is a finite direct sum of endomorphisms η_i of A_∞ that act as symmetries β_{g_i} on a half line $[a, +\infty)$.*

(ii) *$F(\mathcal{C} \rtimes \mathcal{S}) \subset G\text{-Loc}_f A$ and $F : \mathcal{C} \rtimes \mathcal{S} \rightarrow G\text{-Loc}_f A$ is a functor of G -graded categories, i.e. $F((\mathcal{C} \rtimes \mathcal{S})_g) \subset (G\text{-Loc}_f A)_g$ for all $g \in G$.*

Proof. Claim (i) clearly follows from (ii). In order to prove the latter it is sufficient to show for every irreducible object $(\rho, p) \in \mathcal{C} \rtimes \mathcal{S}$ that $E((\rho, p)) \in \text{End } A_\infty$ is $\partial(\rho, p)$ -localized. Let thus $\rho \in \mathcal{C} = \text{Loc}_f A^G$ be localized in the interval $I \in \mathcal{K}$ and let $p = p^2 = p^*$ be a minimal projection in $\text{End}_{\mathcal{C} \rtimes_0 \mathcal{S}}(\rho)$. Recall that $F((\rho, p))$ is defined as $v^*E(\rho)(\cdot)v$, where $v \in A_\infty$ satisfies $vv^* = F(p)$, $v^*v = 1$. We may assume that $v \in A(I)$. Let $J \in \mathcal{K}$ such that $I < J$ and let $H_\gamma \subset A(J)$ be a subspace of isometries transforming under the left regular representation of G . (I.e., we have isometries $v_g \in A(I)$, $g \in G$ such that $\beta_k(v_g) = v_{kg}$, $\sum_g v_v v_g^* = 1$, $v_g^* v_h = \delta_{g,h} 1$.) Let

$\gamma(\cdot) = \sum_g v_g \cdot v_g^* \in \text{End } A_\infty^G$ be the localized endomorphism implemented by H_γ . Thus $H_\gamma = \text{Hom}_A(\mathbf{1}, E(\gamma))$. Now by Theorem 3.8 we have, for $x \in H_\gamma$,

$$F((\rho, p))(x) = v^*c(\gamma, \rho)xv = [E(\gamma)(v^*)c(\rho, \gamma)c(\gamma, \rho)E(\gamma)(v)]x,$$

where we have used (i) $xv = vx$ (since x, v are localized in the disjoint intervals I, J , respectively), (ii) $c(\rho, \gamma) = 1$ (follows by Lemma 2.17 since the localization region of ρ is in the left complement of the localization region of γ) and (iii) $E(\gamma)(v) = v$ (since $v \in A(I)$, on which $E(\rho)$ acts trivially). This expression defines an element of $\text{Hom}_A(F((\rho, p), F(\gamma)F((\rho, p)))$. If $v_1, \dots, v_{|G|} \in \text{Hom}_A(\mathbf{1}, E(\gamma))$ are such that $\sum_i v_i v_i^* = \mathbf{1}$, $v_i^* v_j = \delta_{i,j} \mathbf{1}$ then

$$v_i^* [E(\gamma)(v^*)c(\rho, \gamma)c(\gamma, \rho)E(\gamma)(v)]x \in \text{End}_A(F(\rho, p)).$$

By irreducibility of $F((\rho, p))$ this expression is a multiple of $\text{id}_{F(\rho, p)}$, thus

$$\begin{aligned} d((\rho, p)) F((\rho, p))(x) &= d(\rho, p) [E(\gamma)(v^*)c(\rho, \gamma)c(\gamma, \rho)E(\gamma)(v)]x \\ &= \sum_i v_i \text{Tr}_{(\rho, p)}(v_i^* [E(\gamma)(v^*)c(\rho, \gamma)c(\gamma, \rho)E(\gamma)(v)]x) \end{aligned}$$

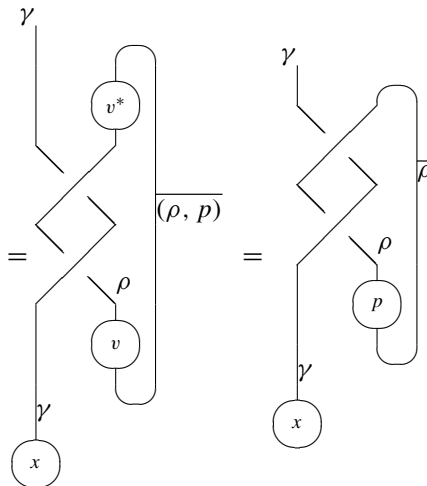

Now we express this as a diagram in \mathcal{C} in terms of the representers $x \in \text{Hom}_{\mathcal{C}}(\gamma, \gamma)$ and $p \in \text{Hom}_{\mathcal{C}}(\gamma \otimes \rho, \rho)$. By definition of $\mathcal{C} \rtimes \mathcal{S}$ we obtain

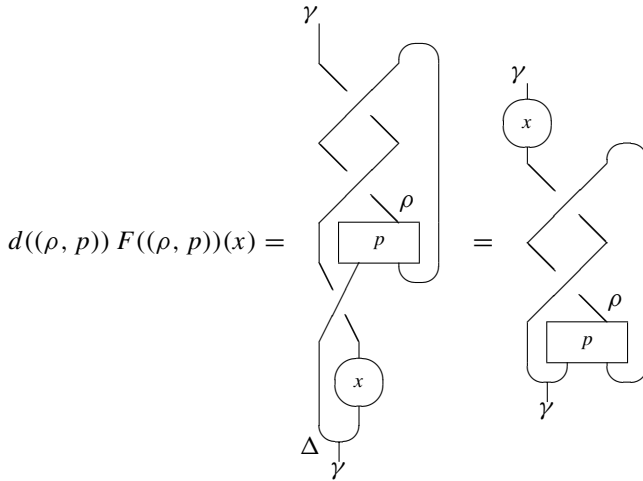

where we have used the commutativity $\Delta = c(\gamma, \gamma) \circ \Delta$. Thus by (3.1) and [48] we have

$$F((\rho, p))(x) = x \circ \partial((\rho, p))^{-1},$$

where $\partial((\rho, p)) \in \text{Aut}(\gamma, m, \eta)$ is the degree of (ρ, p) . Recalling that the action of $g \in \text{Aut}(\gamma, m, \eta)$ on the morphism $s \in \text{Hom}_{\mathcal{C}}(\gamma \otimes \rho, \sigma) \cong \text{Hom}_{\mathcal{C} \rtimes \mathcal{S}}(\rho, \sigma)$ was defined as $\gamma_g(s) = s \circ g^{-1} \otimes \text{id}_\rho$, we see that $F((\rho, p))(x) = \gamma_{\partial((\rho, p))}(x)$. Thus $F((\rho, p)) \in \text{End } A_\infty$ is $\partial(\rho, p)$ -localized in the sense of Sect. 2, as claimed. Transportability of $E((\rho, p))$ follows from transportability of ρ . Thus $E((\rho, p)) \in G\text{-Loc}_f A$, and the same clearly follows for the non-simple objects of $\text{Loc}_f A$. The above computations have also shown that the functor F respects the G -gradings of $\mathcal{C} \rtimes \mathcal{S}$ and $G\text{-Loc } A$ in the sense that $F((\mathcal{C} \rtimes \mathcal{S})_g) \subset (G\text{-Loc}_f A)_g$ for all $g \in G$. \square

The following result, which shows that $\text{Loc}_f A^G$ can be computed from $G\text{-Loc}_f A$, was the main motivation for this paper:

Theorem 3.12. *If G is finite then the functors*

$$\begin{aligned} E : \text{Loc}_f A^G &\rightarrow (G\text{-Loc}_f A)^G, \\ R : (G\text{-Loc}_f A)^G &\rightarrow \text{Loc}_f A^G \end{aligned}$$

are mutually inverse and establish an isomorphism of strict braided tensor categories.

Proof. By Subject. 3.2, $E : \text{Loc}_f A^G \rightarrow (\text{End } A)^G$ is a faithful strict tensor functor, which is full by Proposition 3.10. By Proposition 3.11 it takes its image in $(G\text{-Loc}_f A)^G$. By Theorem 3.8 we have $R \circ E = \text{id}_{\text{Loc}_f A^G}$, and $E \circ R = \text{id}_{(G\text{-Loc}_f A)^G}$ follows since $\rho \in (G\text{-Loc}_f A)^G$ is the unique right-localized extension to A_∞ of $R(\rho) = \rho \upharpoonright A_\infty^G$. Therefore E is surjective on objects and thus an isomorphism. That the braidings of $\text{Loc}_f A^G$ and $(G\text{-Loc}_f A)^G$ is clear in view of their construction. \square

Remark 3.13. 1. The ‘size’ of $\text{Loc}_f A^G$ will be determined in Corollary 3.16.

2. Clearly the above is a somewhat abstract result, and in concrete models hard work is required to determine the category $G\text{-Loc}_f A$ of twisted representations. (For a beautiful analysis of orbifolds of affine models in the present axiomatic setting see the series of papers [64, 37, 27].) However, Theorem 3.12 can be used to clarify the structure of $\text{Loc}_f A^G$ quite completely in the holomorphic case, cf. Subsect. 4.2.

3. Proposition 3.11 and Theorem 3.12 remain true when G is compact infinite. In order to see this one needs to show that $\mathcal{C} \rtimes \mathcal{S}$ is a braided crossed G -category also in the case of infinite \mathcal{S} . In view of the fact that the existence of $\mathcal{C} \rtimes \mathcal{S}$ as a rigid tensor category with G -action was already established in [44] this can be done by an easy modification of the approach used in [48]. Then the proof of Proposition 3.10 easily adapts to arbitrary compact groups.

3.5. *The equivalence $\text{Loc}_f A^G \rtimes \mathcal{S} \simeq G\text{-Loc}_f A$.* Our next aim is to show that the functor F gives rise to an equivalence $\text{Loc}_f A^G \rtimes \mathcal{S} \simeq G\text{-Loc}_f A$ of braided crossed G -categories. (Even though both categories are strict as monoidal categories and as G -categories, the functor F will not be strict.) For the well known definition of a non-strict monoidal functor we refer, e.g., to [40].

Proposition 3.14. *If G is finite then the functor $F : \mathcal{C} \rtimes \mathcal{S} \rightarrow G\text{-Loc}_f A$ is essentially surjective, thus a monoidal equivalence.*

Proof. The bulk of the proof coincides with that of [42, Prop. 3.14], which remains essentially unchanged. We briefly recall the construction. Pick an interval $I \in \mathcal{K}$. Since the G -action on $A(I)$ has full spectrum we can find isometries $v_g \in A(I)$, $g \in G$, satisfying

$$\sum_g v_g v_g^* = \mathbf{1}, \quad v_g^* v_h = \delta_{g,h} \mathbf{1}, \quad \beta_g(v_h) = v_{gh}.$$

If now $\rho \in G\text{-Loc}_f A$ is simple then it is easily verified that

$$\tilde{\rho}(\cdot) = \sum_g v_g \beta_g \rho \beta_{g^{-1}}(\cdot) v_g^* \in G\text{-Loc}_f A$$

commutes with all β_g , thus $\tilde{\rho} \in (G\text{-Loc}_f A)^G$. Therefore $\tilde{\rho}$ restricts to A^G , and $\tilde{\rho} \upharpoonright A^G$ is localized in some interval, as was noted before. In order to show that $\tilde{\rho} \upharpoonright A^G$ is transportable, let J be some interval, let σ be G -localized in J and let $s : \rho \rightarrow \sigma$ be unitary. Choosing isometries $w_g \in A(J)$ as before and defining $\tilde{\sigma}$ in analogy to $\tilde{\rho}$ and writing $\tilde{s} = \sum_g w_g \beta_g(s) v_g^*$, one easily verifies that \tilde{s} is a unitary in $\text{Hom}(\tilde{\rho}, \tilde{\sigma})^G$. Thus $\tilde{\rho} \upharpoonright A_\infty^G$ is transportable and defines an object of $\text{Loc}_f A^G$. As in [42] one now verifies that $\tilde{\rho} = E(\tilde{\rho} \upharpoonright A^G)$. Combined with the obvious fact $\rho \prec \tilde{\rho}$ this implies that every simple object $\rho \in G\text{-Loc}_f A$ is a direct summand of $E(\tilde{\rho} \upharpoonright A^G) = F(\iota(\tilde{\rho} \upharpoonright A^G))$. In view of Proposition 3.10 and the fact that $\mathcal{C} \rtimes \mathcal{S}$ has splitting idempotents we conclude that $\rho \cong F(\sigma)$ for some subobject σ of $\iota(\tilde{\rho} \upharpoonright A^G) \in \mathcal{C} \rtimes \mathcal{S}$. This implies that F is essentially surjective, thus an equivalence, which can be made monoidal, see e.g. [56]. \square

Remark 3.15. In Minkowski spacetimes of dimension $\geq 2 + 1$, where there are no g -twisted representations, the functor E can be shown to be an equivalence under the weaker assumption that G is second countable, i.e. has countably many irreps, cf. [8]. Returning to the present one-dimensional situation, it is clear from the definition of E that $E(\text{Loc}_f A^G \cap \mathcal{S}') \subset \text{Loc}_f A = (G\text{-Loc}_f A)_e$, thus those $\rho \in \text{Loc}_f A^G$ which satisfy $c_{\rho,\sigma} c_{\sigma,\rho} = \text{id}$ for all $\sigma \in \mathcal{S}$ have a localized extension $E(\rho)$. It seems reasonable to expect that the restriction of F to the subcategory of $\mathcal{C} \rtimes \mathcal{S}$ generated by $\iota(\mathcal{C} \cap \mathcal{S}')$ is an equivalence with $\text{Loc}_f A$ whenever G is second countable. We have refrained from going into this question since we are interested in the larger categories $\text{Loc}_f A^G$ and $G\text{-Loc}_f A$, and – in contradistinction to $E : \text{Loc}_f A^G \rightarrow (G\text{-Loc}_f A)^G$ – the functor $F : \text{Loc}_f A \rtimes \mathcal{S} \rightarrow G\text{-Loc}_f A$ is almost never essentially surjective (thus an equivalence). The point is that for $\rho \in \text{Loc}_f A^G$ we have $E(\rho) \cong \bigoplus_i \rho_i$, where the ρ_i are g_i -localized and the g_i exhaust a whole conjugacy class since $E(\rho)$ is G -invariant. Since the direct sum is finite, we see that the image of $E : \mathcal{C} \rtimes \mathcal{S} \rightarrow G\text{-Loc}_f A$ can contain only objects σ whose degree $\partial\sigma$ belongs to a finite conjugacy class. Since ‘most’ infinite non-abelian compact groups have infinite conjugacy classes, F will in general not be essentially surjective. (At least morally this is related to the fact [33] that the quantum double of a compact group G admits infinite dimensional irreducible representations whenever G has infinite conjugacy classes.) If, on the other hand, we consider $E(\rho)$, where $d(\rho) = \infty$, the analysis of $E(\rho)$ becomes considerably more complicated.

Corollary 3.16. *Under the assumptions of Theorem 3.18 we have*

$$\dim \text{Loc}_f A^G = |G| \dim G\text{-Loc}_f A.$$

Proof. Follows from $G\text{-Loc}_f A \cong \text{Loc}_f A^G \rtimes \mathcal{S}$ and $\dim \mathcal{C} \rtimes \mathcal{S} = \dim \mathcal{C} / \dim \mathcal{S} = \dim \mathcal{C} / |G|$, cf. [44]. \square

In order to prove the equivalence $G\text{-Loc}_f A \simeq \text{Loc}_f A^G \rtimes \mathcal{S}$ of braided crossed G -categories we need to consider the G -actions and the braidings. For the general definition of functors of G -categories we refer to [58], see also [7] and the references given there. Since our categories are strict as tensor categories and as G -categories, i.e.

$$\begin{aligned} \gamma_{gh}(X) &= \gamma_g \circ \gamma_h(X) && \forall g, h, X, \\ \gamma_g(X \otimes Y) &= \gamma_g(X) \otimes \gamma_g(Y) && \forall g, X, Y, \end{aligned} \tag{3.3}$$

we can simplify the definition accordingly:

Definition 3.17. *A functor $F : \mathcal{C} \rightarrow \mathcal{C}'$ of categories with strict actions γ_g, γ'_g of a group G is a functor together with a family of natural isomorphisms $\eta(g) : F \circ \gamma_g \rightarrow \gamma'_g \circ F$ such that*

$$\begin{array}{ccc} F \circ \gamma_{gh}(X) & \xrightarrow{\eta(gh)_X} & \gamma'_{gh} \circ F(X) \\ \parallel & & \parallel \\ F \circ \gamma_g \circ \gamma_h(X) & \xrightarrow{\eta(g)_{\gamma_h(X)}} \gamma'_g \circ F \circ \gamma_h(X) \xrightarrow{\gamma'_g(\eta(h)_X)} & \gamma'_g \circ \gamma'_h \circ F(X) \end{array}$$

commutes. (There is no further condition on F if $\mathcal{C}, \mathcal{C}', \gamma, \gamma'$ are monoidal.)

A functor of braided crossed G -categories is a monoidal functor of G -categories that respects the gradings and satisfies $F(c_{X,Y}) = c_{F(X),F(Y)}$ for all $X, Y \in \mathcal{C}$.

Theorem 3.18. *Let $A = (\mathcal{H}_0, A(\cdot), \Omega)$ be as before and G finite. Then*

$$F : \mathcal{C} \rtimes \mathcal{S} \rightarrow G\text{-Loc}_f A$$

is an equivalence of braided crossed G -categories.

Proof. It only remains to show that F is a functor of G -categories and that it preserves the braidings. Let $(\rho, p) \in \mathcal{C} \rtimes \mathcal{S}$. Then $\beta_g((\rho, p)) = (\rho, \beta_g(p))$, where $\beta_g(p)$ is the obvious G -action on $\mathcal{C} \rtimes_0 \mathcal{S}$. Recall that $F((\rho, p)) \in \text{End } A_\infty$ was defined as $v_{(\rho,p)}^* E(\rho)(\cdot) v_{(\rho,p)}$, where $v_{(\rho,p)} \in A_\infty$ satisfies $v_{(\rho,p)} v_{(\rho,p)}^* = E(p)$. (For $p = 1$ we choose $v_{(\rho,p)} = 1$.) Since $E(\rho)$ commutes with γ_g we have $\gamma_g(F((\rho, p))) = \gamma_g(v_{(\rho,p)}^* E(\rho)(\cdot) \gamma_g(v_{(\rho,p)}))$. Because of $\gamma_g(v_{(\rho,p)}) \gamma_g(v_{(\rho,p)})^* = \gamma_g(p)$, the isometries $\gamma_g(v_{(\rho,p)})$ and $v_{\beta_g(\rho,p)}$ have the same range projection. Thus $\eta(g)_{(\rho,p)} = \gamma_g(v_{(\rho,p)})^* v_{(\rho,\beta_g(p))}$ is unitary and one easily verifies $\eta(g)_{(\rho,p)} \in \text{Hom}(F \circ \beta_g(\rho, p), \gamma_g \circ F(\rho, p))$ as well as the commutativity of the above diagram.

It remains to show that the functor F preserves the braidings. We first show that $F(c_{\rho,\sigma}) = c_{F(\rho),F(\sigma)}$ holds if $\rho, \sigma \in \mathcal{C} = \text{Loc}_f A^G$. By Theorem 3.8, $E(\rho), E(\sigma)$ are G -invariant, thus by the G -covariance of the braiding we have $c_{E(\rho),E(\sigma)} \in A_\infty^G$. Thus the braiding of $E(\rho), E(\sigma)$ as constructed in Sect. 2 restricts to a braiding of ρ, σ and by uniqueness of the latter this restriction coincides with $c_{\rho,\sigma}$. Thus $c_{E(\rho),E(\sigma)} = E(c_{\rho,\sigma})$ as claimed. The general result now is an obvious consequence of the naturality of the braidings of $\mathcal{C} \rtimes \mathcal{S}$ and of $G\text{-Loc}_f A$ together with the fact that every object of $\mathcal{C} \rtimes \mathcal{S}$ and of $G\text{-Loc}_f A$ is a subobject of one in \mathcal{C} and $(G\text{-Loc}_f A)^G$, respectively. \square

4. Orbifolds of Completely Rational Chiral CFTs

4.1. General theory. So far, we have considered an arbitrary QFT A on \mathbb{R} subject to the technical condition that also A^G be a QFT on \mathbb{R} , some of the results assuming finiteness of G . The situation that we are really interested is the one where A derives from a chiral QFT on S^1 by restriction to \mathbb{R} . Recall that in that case $\text{Loc}_{(f)} A^G$ has a ‘physical’ interpretation as a category $\text{Rep}_{(f)} A$ of representations.

Proposition 4.1. *Let A be a completely rational chiral QFT with finite symmetry group G . Then the restrictions to \mathbb{R} of A and A^G are QFTs on \mathbb{R} .*

Proof. In view of the discussion in Subsect. 2.4 it suffices to know that the chiral orbifold theory A^G on S^1 satisfies strong additivity. In [64] it was proven that finite orbifolds of completely rational chiral QFTs are again completely rational, in particular strongly additive. \square

Applying the results of [29] we obtain:

Theorem 4.2. *Let $(\mathcal{H}_0, A, \Omega)$ be a completely rational chiral CFT and G a finite symmetry group. Then the braided crossed G -category $G\text{-Loc}_f A$ has full G -spectrum, i.e. for every $g \in G$ there is an object $\rho \in G\text{-Loc}_f A$ such that $\partial \rho = g$. Furthermore, for every $g \in G$ we have*

$$\sum_{\rho \in (G\text{-Loc}_f A)_g} (\dim \rho)^2 = \sum_{\rho \in \text{Rep}_f A} (\dim \rho)^2 = \mu(A),$$

where the sums are over the equivalence classes of irreducible objects of degree g and e , respectively.

Proof. By [64], the fixpoint theory A^G is completely rational, thus by [29] the categories $\text{Rep}_f A^G \cong \text{Loc}_f A^G$ are modular. Now, $G\text{-Loc}_f A \cong \text{Loc}_f A^G \rtimes \mathcal{S}$, and fullness of the G -spectrum follows by [48, Cor. 3.27]. The statement on the dimensions follows from [48, Prop. 3.23]. \square

Remark 4.3. 1. It would be very desirable to give a direct proof of the fullness of the G -spectrum of $G\text{-Loc}_f A$ avoiding reference to the orbifold theory A^G via the equivalence $G\text{-Loc}_f A \simeq \text{Loc}_f A^G \rtimes \mathcal{S}$. This would amount to showing directly that g -localized transportable endomorphisms of A_∞ exist for every $g \in G$. Since our proof relies on the fairly non-trivial modularity result for $\text{Loc}_f A^G$, cf. [29] together with [64], this might turn out difficult.

2. In the VOA setting, Dong and Yamskulna [14] have shown that there exist twisted representations for all $g \in G$. Since [48, Prop. 3.23] is a purely categorical result, the above conclusion also holds in the VOA setting as soon as one can establish that the G -twisted representations form a rigid tensor category.

3. It may be useful to summarize the situation in a diagram:

$$\begin{array}{ccc}
 \text{Loc}_f A & \subset & G\text{-Loc}_f A \\
 \downarrow \uparrow & & \downarrow \uparrow \\
 \mathcal{C} \rightsquigarrow \mathcal{C}^G & & \mathcal{C} \rightsquigarrow \mathcal{C} \rtimes \mathcal{S} \\
 \downarrow \uparrow & & \downarrow \uparrow \\
 \text{Loc}_f A^G \cap \mathcal{S}' & \subset & \text{Loc}_f A^G
 \end{array}$$

The horizontal inclusions are full, $\text{Loc}_f A$ being the degree zero subcategory of $G\text{-Loc}_f A$. If G is abelian, the G -grading passes to $\text{Loc}_f A^G$ (see [48]) and $\text{Loc}_f A^G \cap \mathcal{S}'$ is its degree zero subcategory. Moving from left to right or from top to bottom, the dimension of the categories are multiplied by $|G|$. In the upper line this is due to Theorem 4.2 and in the lower due to the results of [47]. Together with $\dim \mathcal{C} = |G| \cdot \dim \mathcal{C} \rtimes \mathcal{S}$ this implies $\dim \text{Loc}_f A^G = |G|^2 \dim \text{Loc}_f A$, as required by [29]. (In fact, this latter identity together with [48, Prop. 3.23] provides an alternative proof of the completeness of the G -spectrum of $G\text{-Loc}_f A$.) Furthermore, the upper left and lower right categories are modular, whereas $\text{Loc}_f A^G \cap \mathcal{S}'$ is not (whenever $G \neq \{e\}$). The passage $\text{Loc}_f A^G \cap \mathcal{S}' \rightsquigarrow \text{Loc}_f A$ is the ‘modular closure’ from [44, 5] and $\text{Loc}_f A^G \cap \mathcal{S}' \rightsquigarrow \text{Loc}_f A^G$ is the ‘minimal modularization’, conjectured to exist for every premodular category, cf. [47].

We briefly discuss the modularity of $G\text{-Loc}_f A$. In [60], a braided crossed G -category \mathcal{C} was called modular if its braided degree zero subcategory \mathcal{C}_e is modular in the usual sense [59]. This definition seems somewhat unsatisfactory since it does not take the nontrivially graded part of \mathcal{C} into account. In [31], the vector space

$$\mathcal{V}_{\mathcal{C}} = \bigoplus_{i \in I} \bigoplus_{g \in G} \text{Hom}(\beta_g(X_i), X_i),$$

where I indexes the isomorphism classes of simple objects in \mathcal{C} , is introduced and an endomorphism $S \in \text{End } \mathcal{V}_{\mathcal{C}}$ is defined by its matrix elements

$$S((X, u), (Y, v)) =$$

where $\partial X = g$, $\partial Y = h$ and $u : \beta_h(X) \rightarrow X$, $v : \beta_g(Y) \rightarrow Y$. A braided G -crossed fusion category is modular (in the sense of [31]) if the endomorphism S is invertible.

Proposition 4.4. *Let $(\mathcal{H}_0, A, \Omega)$ be a completely rational chiral CFT and G a finite symmetry group. Then the braided crossed G -category $G - \text{Loc}_f A$ is modular in the sense of [31].*

Proof. As used above, the braided categories $\text{Loc}_f A = (G - \text{Loc}_f A)_e$ and $\text{Loc}_f A^G \cong (G - \text{Loc}_f A)^G$ are modular. Now the claim follows by [31, Theorem 10.5]. \square

The preceding discussions have been of a very general character. In the next subsection they will be used to elucidate completely the case of holomorphic orbifolds, where our results go considerably beyond (and partially diverge from) those of [11]. In the non-holomorphic case it is clear that comparably complete results cannot be hoped for. Nevertheless already a preliminary analysis leads to some surprising results and counterexamples, cf. the final subsection.

4.2. Orbifolds of holomorphic models.

Definition 4.5. *A holomorphic chiral CFT is a completely rational chiral CFT with trivial representation category $\text{Loc}_f A$. (I.e., $\text{Loc}_f A$ is equivalent to $\text{Vect}_f \mathbb{C}$.)*

Remark 4.6. By the results of [29], a completely rational chiral CFT is holomorphic iff $\mu(A) = 1$ iff $A(E') = A(E)'$ whenever $E = \cup_{i=1}^n I_i$, where $I_i \in \mathcal{I}$ with mutually disjoint closures.

Corollary 4.7. *Let A be a holomorphic chiral CFT acted upon by a finite group G . Then $G - \text{Loc}_f A$ has precisely one isomorphism class of simple objects for every $g \in G$, all of these objects having dimension one.*

Proof. By Theorem 4.2, we have $\dim(G - \text{Loc}_f A)_g = 1$ for all $g \in G$. Since the dimensions of all objects are ≥ 1 , the result is obvious. \square

Remark 4.8. 1. In [43], where the invertible objects of $G\text{-Loc}_f A$ were called soliton automorphisms, it is shown that these objects can be studied in a purely local manner.

2. Let A be a holomorphic chiral CFT, and pick an interval $I \in \mathcal{K}$. By Corollary 4.7 there is just one isoclass of simple objects in $(G\text{-Loc}_f A)_g$ for every $g \in G$. Since the objects of $G\text{-Loc}_f A$ are transportable endomorphisms of A_∞ , we can pick, for every $g \in G$, representer ρ_g that is g -localized in I . By Lemma 2.12, ρ_g restricts to an automorphism of $A(I)$. Furthermore, we can choose unitaries $u_{g,h} \in \text{Hom}_{A(I)}(\rho_g \rho_h, \rho_{gh})$. In other words, we have a homomorphism

$$G \rightarrow \text{Aut}A(I)/\text{Inn}A(I) =: \text{Out}A(I), \quad g \mapsto [\rho_g],$$

thus a ‘ G -kernel’, cf. [57]. We recall some well known facts: The associativity $(\rho_g \rho_h) \rho_k = \rho_g (\rho_h \rho_k)$ implies the existence of $\alpha_{g,h,k} \in \mathbb{T}$ such that

$$u_{gh,k} u_{g,h} = \alpha_{g,h,k} u_{g,hk} \rho_g(u_{h,k}) \quad \forall g, h, k.$$

A tedious but straightforward computation using four ρ ’s shows that $\alpha : G \times G \times G \rightarrow \mathbb{T}$ is a 3-cocycle, whose cohomology class $[\alpha] \in H^3(G, \mathbb{T})$ does not depend on the choice of the ρ ’s and of the u ’s. Thus $[\alpha]$ is an obstruction to the existence of representers ρ_g for which $g \mapsto \rho_g$ is a homomorphism $G \rightarrow \text{Aut}A(I)$. (Actually, since in QFT the algebras $A(I)$ are type III factors with separable preduel, the converse is also true: If $[\alpha] = 0$ then one can find a homomorphism $g \mapsto \rho_g$, cf. [57].)

4.9. For a further analysis it is more convenient to adopt a purely categorical viewpoint. Starting with the category $G\text{-Loc}_f A$ of a holomorphic theory A , we don’t lose any information by throwing away the non-simple objects and the zero morphisms. In this way we obtain a categorical group \mathcal{C} , i.e. a monoidal groupoid where all objects have a monoidal inverse. The set of isoclasses is the group G . In the general k -linear case it is well known that such categories are classified up to equivalence by $H^3(G, k^*)$. This is shown by picking an equivalent skeletal tensor category $\tilde{\mathcal{C}}$, i.e. a full subcategory with one object per isomorphism class. Even if \mathcal{C} is strict, $\tilde{\mathcal{C}}$ in general is not, and the associativity constraint defines an element of $H^3(G, k^*)$. It is thus clear that 3-cocycles on G will play a rôle in the classification of the braided crossed G -categories associated with holomorphic QFTs. In view of [11, 10, 12] and [13, 14] this is hardly surprising. Yet, the situation is somewhat more involved than anticipated by most authors since a classification of the possible categories $G\text{-Loc}_f A$ – and therefore of the categories $\text{Loc}_f A^G$ – must also take the G -action on $G\text{-Loc}_f A$ and the braiding into account.

If one considers *braided* categorical groups, G must be abelian and one has a classification in terms of $H^3_{\text{ab}}(G, k^*)$, cf. [25]. ($H^3_{\text{ab}}(G, k^*)$ is Mac Lane’s cohomology [38] for abelian groups.) The requirement that G be abelian disappears if one admits a non-trivial G -action and considers braided crossed G -categories. One finds [60] that (non-strict) skeletal braided crossed G -categories with strict G -action in the sense of (3.3) are classified in terms of Ospel’s quasiabelian cohomology $H^3_{\text{qa}}(G, k^*)$ [51]. Unfortunately, this is still not sufficient for our purposes. Namely, assume we have a braided crossed G -category \mathcal{C} that is also a categorical group (and thus a categorical G -crossed module in the sense of [7]). Even if \mathcal{C} is strict monoidal and satisfies (3.3) – as our categories $G\text{-Loc} A$ and $\mathcal{C} \rtimes \mathcal{S}$ do – an equivalent skeletal category $\tilde{\mathcal{C}}$ in general will not satisfy (3.3). It is clear that for a completely general classification of braided crossed G -categories that are categorical groups one can proceed along similar lines as in the classifications cited above. We will supply the details in the near future [49], also elucidating the rôle of the twisted quantum doubles $D^\omega(G)$ [10] in the present context. (Note that the modular

category $D^\omega - \text{Mod}$ contains the symmetric category $G - \text{Mod}$ as a full subcategory, and $D^\omega - \text{Mod} \rtimes G - \text{Mod}$ is a braided crossed G -category with precisely one invertible object of every degree. However, not every such category is equivalent to $D^\omega - \text{Mod} \rtimes G - \text{Mod}$ for some $[\omega] \in H^3(G, \mathbb{T})!$

4.3. Some observations on non-holomorphic orbifolds. In the previous subsection we have seen that a holomorphic chiral CFT A has (up to isomorphism) exactly one simple object of degree $g \in G$, and this object has dimension one, thus is invertible. This allows a complete classification of the categories $G - \text{Loc}A$ and $\text{Loc}A^G \cong (G - \text{Loc}A)^G$ that can arise.

It is clear that in the non-holomorphic case ($\text{Loc}_f A \not\cong \text{Vect}_{\mathbb{C}}$) there is no hope of obtaining results of this completeness. The best one could hope for would be a classification of the categories $G - \text{Loc}_f A$ that can arise from CFTs with prescribed $\text{Loc}_f A \simeq (G - \text{Loc}_f A)_e$, but for the time being this is far out of reach. We therefore content ourselves with some comments on a more modest question. To wit, we ask whether a non-holomorphic completely rational CFT A admits *invertible* g -twisted representations for every $g \in G$. (As we have seen, this is the case for holomorphic A .) It turns out that the existence of a braiding (in the sense of crossed G -categories) provides an obstruction:

Lemma 4.10. *Let \mathcal{C} be a braided crossed G -category. If there exists an invertible object of degree $g \in G$ then*

$$\gamma_g(X) \cong X \quad \forall X \in \mathcal{C}_e.$$

Proof. Let $X \in \mathcal{C}_e$ and $Y \in \mathcal{C}_g$. Then the braiding gives rise to isomorphisms $c_{X,Y} : X \otimes Y \rightarrow Y \otimes X$ and $c_{Y,X} : Y \otimes X \rightarrow \gamma_g(X) \otimes Y$. Composing these we obtain an isomorphism $X \otimes Y \rightarrow \gamma_g(X) \otimes Y$. If Y is invertible, we can cancel it by tensoring with \bar{Y} , obtaining the desired isomorphism $X \xrightarrow{\cong} \gamma_g(X)$. \square

Corollary 4.11. *Let \mathcal{C} be a braided crossed G -category and let $g \in G$. If there exists $X \in \mathcal{C}_e$ such that $\gamma_g(X) \not\cong X$ then there exists no invertible $Y \in \mathcal{C}_g$.*

Remark 4.12. The condition $\gamma_g(X) \cong X \quad \forall X \in \mathcal{C}_e$ is necessary in order for the existence of invertible objects of degree g , but of course not sufficient. In any case, there are many chiral CFTs where the corollary, as applied to $G - \text{Loc}_f A$, excludes invertible g -twisted representations for $g \neq e$. One such class will be considered below.

We apply the above results to the n -fold direct product $A = B^{\otimes n}$ of a completely rational chiral CFT B , on which the symmetric group S_n acts in the obvious fashion. We first note that every irreducible $\pi \in \text{Rep}_f A$ is unitarily equivalent to a direct product $\pi_1 \otimes \cdots \otimes \pi_n$ of irreducible $\pi_i \in \text{Rep}_f B$, cf. [29]. Thus the equivalence classes of simple objects of $\text{Loc}_f A$ are the n -tuples of equivalence classes of simple objects of $\text{Loc}_f B$, and S_n acts on them by permutation.

Corollary 4.13. *Let B be a completely rational chiral CFT and let $n \geq 2$. Consider $A = B^{\otimes n}$ with the permutation action of $G = S_n$. If B is not holomorphic then $G - \text{Loc}_f A$ contains no invertible object ρ with $\partial \rho \neq e$.*

Proof. Since B is not holomorphic we can find a simple object $\sigma \in \text{Loc}_f B$ such that $\sigma \not\cong \mathbf{1}$. If $g \in S_n$ with $g \neq e$ there is $i \in \{1, \dots, n\}$ such that $g(i) \neq i$. Consider an object $\rho = (\rho_1, \dots, \rho_n) \in \text{Loc}_f A$, where $\rho_i = \mathbf{1}$ and $\rho_{g(i)} = \sigma$. Now it is clear that $\gamma_g(\rho) \not\cong \rho$, and Corollary 4.11 applies. \square

For any tensor category \mathcal{C} we denote by $\text{Pic}(\mathcal{C})$ the full monoidal subcategory of invertible objects. (In a $*$ -category these are precisely the objects of dimension one.)

Corollary 4.14. *Let B be a completely rational chiral CFT. Consider $A = B^{\otimes n}$ for $n \geq 2$ and let $G \subset S_n$ be a subgroup. If B is non-holomorphic then*

$$\text{Pic}(\text{Loc}_f A^G) \cong \text{Pic}\left((\text{Loc}_f A)^G\right).$$

Proof. We may assume $G \neq \{e\}$ since otherwise there is nothing to prove. By Theorem 3.12 we have $\text{Loc}_f A^G \cong (G - \text{Loc}_f A)^G$. Let now $\rho \in \text{Pic}(\text{Loc}_f A^G)$. Then $E(\rho) \in \text{Pic}((G - \text{Loc}_f A)^G)$, and by Corollary 4.13 we have $\partial E(\rho) = e$, thus $E(\rho) \in \text{Pic}((\text{Loc}_f A)^G)$. The rest follows as in Subsect. 3.4. \square

Thus, in permutation orbifold models, the Picard category $\text{Pic}(\text{Loc}_f A^G)$ is determined already by $\text{Pic}(\text{Loc}_f A)$ and the G -action on it, i.e. we do not need to know the g -twisted representations of A for $g \neq e$. We recall that a subgroup $G \subset S_n$ is called transitive if for each $i, j \in \{1, \dots, n\}$ there exists $g \in G$ such that $g(i) = j$.

Corollary 4.15. *Let B be a non-holomorphic completely rational chiral CFT. Consider $A = B^{\otimes n}$ for $n \geq 2$ and let $G \subset S_n$ be a transitive subgroup. Then the isomorphism classes in $\text{Pic}(\text{Loc}_f A^G)$ are in 1-1 correspondence with the pairs $([\sigma], \lambda)$, where $[\sigma]$ is an isomorphism class in $\text{Pic}(\text{Loc}_f B)$ and $\lambda \in \widehat{G}_1 = \widehat{G}_{ab}$ is a one-dimensional character of G .*

Proof. Let ρ be an invertible object of $\text{Loc}_f A^G$. By Corollary 4.14, we have $E(\rho) \cong (\sigma_1, \dots, \sigma_n)$ where the σ_i are invertible objects of $\text{Loc}_f B$. By Subsect. 3.2, $E(\rho)$ is invariant under the G -action on $\text{Loc}_f A$, and since the latter transitively permutes the σ_i there is $\sigma \in \text{Pic}(\text{Loc}_f B)$ such that $\sigma_i \cong \sigma$ for all i . Now, by 3.3 we know that for every $\lambda \in \widehat{G}_1$ there exist localized unitaries $u_\lambda \in A_\infty$ such that $\beta_g(u_\lambda) = \lambda(g)u_\lambda$. In restriction to A_∞^G , the localized isomorphisms $\text{Ad } u_\lambda$ are inequivalent invertible objects $\rho_\lambda \in \text{Pic}(\text{Loc}_f A^G)$. Now the claimed bijection follows by picking one representer σ for each isoclass $[\sigma]$ in $\text{Pic}(\text{Loc}_f B)$ and mapping $([\sigma], \lambda) \mapsto [(\sigma, \dots, \sigma) \otimes \rho_\lambda]$. \square

Remark 4.16. Corollary 4.15 is incompatible with some claims in [1] on the representation category of cyclic orbifolds, for which no rigorous proofs are available, cf. also [39]. More precisely, in [1, 2] cyclic permutation orbifolds $(B^{\otimes n})^{\mathbb{Z}_n}$ are considered, where $\mathbb{Z}_n \subset S_n$ acts by cyclic permutations on $A = B^{\otimes n}$, thus transitively. According to [1, 2] the set of isoclasses of simple objects of $\text{Rep}_f A^{\mathbb{Z}_n}$ contains a subset $\mathcal{I} = \{([X], i, j)\}$, where $[X]$ is a simple isoclass in $\text{Rep}_f B$ and $i, j \in \mathbb{Z}/n\mathbb{Z}$. Accepting this for a minute, it follows from the modular S -matrix given in [2] that if X is invertible (' X is a simple current of B '), also the objects $([X], i, j)$ in $\text{Rep}_f A^{\mathbb{Z}_n}$ are invertible. Thus according to [1, 2], $\text{Rep}_f A^{\mathbb{Z}_n}$ contains at least $n^2 m$ isoclasses of invertible objects, where m is the number of isoclasses of invertible objects of $\text{Rep}_f B$. On the other hand, Corollary 4.15 implies that $\text{Rep}_f A^{\mathbb{Z}_n}$ contains precisely nm isoclasses of invertible objects. Since $n \geq 2$ and $m \geq 1$ this is a contradiction.

The claims in question play a crucial rôle in [2] which attempts to prove that the kernel of the representation of $SL(2, \mathbb{Z})$ arising from a rational CFT contains a congruence subgroup $\Gamma(N)$. We leave it to the reader to draw his/her conclusions.

Acknowledgements. The research reported here was presented at the workshop ‘Tensor Categories in Mathematics and Physics’ which took place at the Erwin Schrödinger Institute, Vienna, in June 2004. I am grateful to the ESI for hospitality and financial support and to the organizers for the invitation to a very stimulating meeting.

References

1. Bantay, P.: Characters and modular properties of permutation orbifolds. *Phys. Lett.* **B419**, 175–178 (1998); *Permutation orbifolds. Nucl. Phys.* **B633**, 365–378 (2002)
2. Bantay, P.: The kernel of the modular representation and the Galois action in RCFT. *Commun. Math. Phys.* **233**, 423–438 (2003)
3. Barrett, J.W., Westbury, B.W.: Spherical categories. *Adv. Math.* **143**, 357–375 (1999)
4. Böckenhauer, J., Evans, D.E.: Modular invariants, graphs and α -induction for nets of subfactors I. *Commun. Math. Phys.* **197**, 361–386 (1998)
5. Bruguières, A.: Catégories prémodulaires, modularisations et invariants de variétés de dimension 3. *Math. Ann.* **316**, 215–236 (2000)
6. Brunetti, R., Guido, D., Longo, R.: Modular structure and duality in QFT. *Commun. Math. Phys.* **156**, 201–219 (1993)
7. Carrasco, P., Moreno, J.M.: Categorical G-crossed modules and 2-fold extensions. *J. Pure Appl. Alg.* **163**, 235–257 (2001)
8. Conti, R., Doplicher, S., Roberts, J.E.: On subsystems and their sectors. *Commun. Math. Phys.* **218**, 263–281 (2001)
9. Deligne, P.: Catégories tannakiennes. In: *Grothendieck Festschrift*, P. Cartier et al. (eds.), Vol. **II**, Basel-Boston: Birkhäuser Verlag, 1991, pp. 111–195
10. Dijkgraaf, R., Pasquier, V., Roche, P.: Quasi Hopf algebras, group cohomology and orbifold models. *Nucl. Phys. B (Proc. Suppl.)* **18B**, 60–72 (1990)
11. Dijkgraaf, R., Vafa, C., Verlinde, E., Verlinde, H.: The operator algebra of orbifold models. *Commun. Math. Phys.* **123**, 485–527 (1989)
12. Dijkgraaf, R., Witten, E.: Topological gauge theories and group cohomology. *Commun. Math. Phys.* **129**, 393–429 (1990)
13. Dong, C., Li, H., Mason, G.: Twisted representations of vertex operator algebras. *Math. Ann.* **310**, 571–600 (1998)
14. Dong, C., Yamskulna, G.: Vertex operator algebras, generalized doubles and dual pairs. *Math. Z.* **241**, 397–423 (2002)
15. Doplicher, S., Haag, R., Roberts, J.E.: Fields, observables and gauge transformations I. *Commun. Math. Phys.* **13**, 1–23 (1969)
16. Doplicher, S., Haag, R., Roberts, J.E.: Local observables and particle statistics I & II. *Commun. Math. Phys.* **23**, 199–230 (1971); **35**, 49–85 (1974)
17. Doplicher, S., Roberts, J.E.: Endomorphisms of C^* -algebras, cross products and duality for compact groups. *Ann. Math.* **130**, 75–119 (1989)
18. Doplicher, S., Roberts, J.E.: A new duality theory for compact groups. *Invent. Math.* **98**, 157–218 (1989)
19. Doplicher, S., Roberts, J.E.: Why there is a field algebra with a compact gauge group describing the superselection structure in particle physics. *Commun. Math. Phys.* **131**, 51–107 (1990)
20. Fredenhagen, K., Rehren, K.-H., Schroer, B.: Superselection sectors with braid group statistics and exchange algebras I. General theory. *Commun. Math. Phys.* **125**, 201–226 (1989)
21. Fredenhagen, K., Rehren, K.-H., Schroer, B.: Superselection sectors with braid group statistics and exchange algebras II. Geometric aspects and conformal covariance. *Rev. Math. Phys.* **Special Issue**, 113–157 (1992)
22. Gabbiani, F., Fröhlich, J.: Operator algebras and conformal field theory. *Commun. Math. Phys.* **155**, 569–640 (1993)
23. Guido, D., Longo, R.: Relativistic invariance and charge conjugation in quantum field theory. *Commun. Math. Phys.* **148**, 521–551 (1992)
24. Haag, R.: *Local Quantum Physics*. 2nd ed. Springer Texts and Monographs in Physics, Berlin-Heidelberg-New York: Springer, 1996

25. Joyal, A., Street, R.: Braided tensor categories. *Adv. Math.* **102**, 20–78 (1993)
26. Kac, V.: *Vertex algebras for beginners*. AMS University Lecture Series, Vol. **10**, Providence, RI: AMS 1997
27. Kac, V., Longo, R., Xu, F.: Solitons in affine and permutation orbifolds. *Commun. Math. Phys.* **253**, 723–764 (2005)
28. Kadison, R.V., Ringrose, J.R.: *Fundamentals of the theory of operator algebras II*. New York: Academic Press, 1986
29. Kawahigashi, Y., Longo, R., Müger, M.: Multi-interval subfactors and modularity of representations in conformal field theory. *Commun. Math. Phys.* **219**, 631–669 (2001)
30. Kirillov Jr., A.: Modular categories and orbifold models I & II. *Commun. Math. Phys.* **229**, 309–335 (2002), <http://arxiv.org/abs/math.QA/0110221>, 2001
31. Kirillov Jr., A.: *On G-equivariant modular categories*. <http://arxiv.org/abs/math.QA/0401119>, 2004
32. Kirillov Jr., A., Ostrik, V.: On q-analog of McKay correspondence and ADE classification of $sl(2)$ conformal field theories. *Adv. Math.* **171**, 183–227 (2002)
33. Koornwinder, T.H., Muller, N.: The quantum double of a (locally) compact group. *J. Lie Th.* **7**, 101–120 (1997)
34. Longo, R.: Index of subfactors and statistics of quantum fields I & II. *Commun. Math. Phys.* **126**, 217–247 (1989); **130**, 285–309 (1990)
35. Longo, R., Rehren, K.-H.: Nets of subfactors. *Rev. Math. Phys.* **7**, 567–597 (1995)
36. Longo, R., Roberts, J.E.: A theory of dimension. *K-Theory* **11**, 103–159 (1997)
37. Longo, R., Xu, F.: Topological sectors and a dichotomy in conformal field theory. *Commun. Math. Phys.* **251**, 321–364 (2004)
38. Mac Lane, S.: *Cohomology theory of abelian groups*. Proceedings of the ICM 1950, (Cambridge, MA, 1950) Vol. **II**, Providence, RI: Am. Math. Soc., 1952, pp. 8–14
39. Mac Lane, S.: Despite physicists, proof is essential in mathematics. *Synthese* **111**, 147–154 (1997)
40. Mac Lane, S.: *Categories for the Working Mathematician*. 2nd ed. Berlin-Heidelberg-New York: Springer-Verlag, 1998
41. Moore, G., Seiberg, N.: Classical and quantum conformal field theory. *Commun. Math. Phys.* **123**, 177–254 (1989)
42. Müger, M.: On charged fields with group symmetry and degeneracies of Verlinde’s matrix S . *Ann. Inst. Henri Poincaré B (Phys. Théor.)* **7**, 359–394 (1999)
43. Müger, M.: On soliton automorphisms in massive and conformal theories. *Rev. Math. Phys.* **11**, 337–359 (1999)
44. Müger, M.: Galois theory for braided tensor categories and the modular closure. *Adv. Math.* **150**, 151–201 (2000)
45. Müger, M.: Conformal field theory and Doplicher-Roberts reconstruction. In: *Mathematical Physics in Mathematics and Physics: Quantum and Operator Algebraic Aspects*, R. Longo (ed.), Fields Inst. Commun. **20**, 297–319 (2001)
46. Müger, M.: From subfactors to categories and topology I. Frobenius algebras in and Morita equivalence of tensor categories. *J. Pure Appl. Alg.* **180**, 81–157 (2003)
47. Müger, M.: On the structure of modular categories. *Proc. Lond. Math. Soc.* **87**, 291–308 (2003)
48. Müger, M.: Galois extensions of braided tensor categories and braided crossed G-categories. *J. Alg.* **277**, 256–281 (2004)
49. Müger, M.: *Group actions on braided tensor categories*. In preparation
50. Müger, M., Tuset, L.: *Regular representations of algebraic quantum groups and embedding theorems*. In preparation
51. Ospel, L.: *Tressages et théories cohomologiques pour les algèbres de Hopf. Application aux invariants des 3-variétés*. Thèse, Univ. Strasbourg, 1999
52. Pareigis, B.: On braiding and dyslexia. *J. Algebra* **171**, 413–425 (1995)
53. Rehren, K.-H.: Markov traces as characters for local algebras. *Nucl. Phys. B(Proc. Suppl.)* **18B**, 259–268 (1990)
54. Rehren, K.-H.: Spin-statistics and CPT for solitons. *Lett. Math. Phys.* **46**, 95–110 (1998)
55. Roberts, J.E.: Net cohomology and its applications to field theory. In: *Quantum fields, Particles, Processes*, L. Streit (ed.), Berlin-Heidelberg-New York: Springer, 1980
56. Saaveda Rivano, N.: *Catégories Tannakiennes*. LNM **265**, Berlin-Heidelberg-New York: Springer-Verlag, 1972
57. Sutherland, C.E.: Cohomology and extensions of von Neumann algebras I & II. *Publ. RIMS (Kyoto)* **16**, 105–133, 135–174 (1980)
58. Tambara, D.: Invariants and semi-direct products for finite group actions on tensor categories. *J. Math. Soc. Jap.* **53**, 429–456 (2001)
59. Turaev, V.G.: *Quantum Invariants of Knots and 3-Manifolds*. Berlin: Walter de Gruyter, 1994
60. Turaev, V.G.: *Homotopy field theory in dimension 3 and crossed group-categories*. <http://arxiv.org/abs/math.GT/0005291>, 2000

61. Wassermann, A.: Operator algebras and conformal field theory III. Fusion of positive energy representations of $SU(N)$ using bounded operators. *Invent. Math.* **133**, 467–538 (1998)
62. Xu, F.: New braided endomorphisms from conformal inclusions. *Commun. Math. Phys.* **192**, 349–403 (1998)
63. Xu, F.: Jones-Wassermann subfactors for disconnected intervals. *Commun. Contemp. Math.* **2**, 307–347 (2000)
64. Xu, F.: Algebraic orbifold conformal field theories. *Proc. Natl. Acad. Sci. USA* **97**, 14069–14073 (2000)

Communicated by Y. Kawahigashi